

ALUMINIUM ROLLER SHUTTERS

FOR SPECIAL VEHICLES



SRS
ROLLER SHUTTERS







Index

01	INTRO THE COMPANY	6
02	SRS TOP <small>Roller Shutters</small> SRS TOP - SRS TOP READY - SRS TOP XL	14
03	SRS TOP – E <small>Roller Shutters</small> SRS TOP E STANDARD SERENA MOTOR - SRS TOP E TUBULAR MOTOR	22
04	SRS ECO <small>Roller Shutters</small> SRS ECO - SRS ECO PLUS - SRS ECO SIMPLY - SRS ECO PLUS SIMPLY	28
05	CUSTOM MADE FINISHING - GUIDES - CLOSING SYSTEMS - WINDING ROLLS - ACCESSORIES	34
06	OTHER ARTICLES LADDERS - SLIDES - DRAWERS - LOCKING SYSTEMS - HOSE DIVIDERS - HANDRAILS - BOXES	44

01

INTRO

THE COMPANY

Serena Production is a **family-owned Italian company** based in **Montirone (Brescia)**, with over 50 years of experience in aluminium processing for special vehicles.

Founded in **1973** by **Luigi Serena**, the company began by providing cleaning and finishing services for aluminium profiles used in vehicle bodywork. Through close cooperation with leading Italian body builders, the company soon recognized the potential of an innovative solution: the aluminium roller shutter, designed as a **modern and efficient alternative** to traditional closing systems.

Over the years, Serena Production has specialized in the design and manufacturing of **aluminium roller shutters** specifically developed for special vehicles.

Today the company manages the **entire production process in-house**, from design and aluminium extrusion to the assembly of the profiles, ensuring high quality standards, reliability, and flexibility.

Serena Production roller shutters are marketed under the registered trademark **SRS Roller Shutters**, internationally recognized for their durability, functionality, and refined design.

Entirely manufactured in Italy, SRS products represent the **excellence of Made in Italy**, combining engineering expertise, technical reliability, and continuous innovation to meet the demands of the global special vehicle market.



1973

Foundation of **Pulimetal snc.**

Start of the production of **aluminium roller shutters.**

1976

With the entry of the second generation, **Stefano** and **Alessandro**, into the company management and in response to new business developments, the company transitions to an industrial structure and becomes **Serena Production srl.**

1980

The production activity expands, doubling its operational space and taking the new company name **Serena Pulimetal snc**, based in **Flero** (Brescia).



2004

Relocation and expansion of the company headquarters to **Montirone** (Brescia).



2011

Establishment of **SRS Roller Shutters**, in partnership with the **Fireco Group**, to strengthen the company's presence in international markets



2017

Constantly evolving



2023

Celebrating 50 years as a reference point in the industry: an extraordinary journey driven by people, passion, and vision.



2026

OUR VALUES



Made in Italy Reliability

Every component of the **SRS** products is entirely **manufactured in Italy** – from extrusion and machining to final assembly. This fully integrated production process allows us to guarantee **high quality standards, reliable spare parts availability, and direct technical support.**



High Customization

Our roller shutters can be configured to meet **specific customer requirements.** Options include customized dimensions, different profile models, manual or motorized operation, locking systems, accessories, sensors, LED lighting, and remote controls. **Authorized customer logos** can also be integrated directly into the shutter during the assembly process.



Innovation & Engineering

SRS roller shutters are designed using **advanced aluminium profiles** and carefully selected materials. Each shutter is equipped with appropriately sized winding roll based on its dimensions, adaptable side guides, and profiles finished with micro-sandblasting combined with anodizing or powder coating to ensure both **aesthetic quality** and long-term durability.



Complete Service

From quotation to delivery and after-sales support, we provide **full technical assistance.** Our services include design consultation, installation support, and **continuous availability of spare parts** to ensure **long-term reliability.**

PRODUCTS & ACCESSORIES

Aluminium roller shutters

Available in **manual or electric versions.** Designed for **smooth, quiet, and safe operation,** with compact rolling systems that minimize both internal and external space requirements.

Side guides & curved tracks

Precision-engineered guides and curved rails ensuring reliable sliding performance and optimal integration into vehicle structures.

Aluminium finishing profiles

Extruded aluminium profiles and components designed to support and complete a wide range of vehicle body structures and finishing applications.

Closing systems & Winding rolls

Closing elements, winding systems, and complete kits supplied with mounting support components for efficient installation.

Ladders / Slides / Drawers / Hose dividers

Practical solutions designed to improve **accessibility, movement, and organized storage** of equipment inside the vehicle.

Boxes with Roller Shutter

Modular containers available in **welded or bolted configurations,** designed to be fixed, tilting, or transportable depending on operational needs.

Accessories & Kits

12V / 24V **LED lighting systems** for internal, external, and perimeter illumination, locking kits, and a wide range of customization options.

APPLICATIONS

SRS roller shutters and accessories are designed for a wide range of **special vehicles and industrial applications,** offering reliable protection, easy access, and efficient space management.

Main application sectors include:

- **Electric** vehicles
- **Commercial** vehicles
- **Industrial** vehicles
- **Municipal service** vehicles (road maintenance, street cleaning, waste collection and management)
- **Emergency & Rescue** vehicles (civil protection, fire brigades, government and territorial management services)
- **Boxes, Trailers & Shelters**
- Heavy and light **tricycles & quadricycles**
- Special and **customized** applications

Industrial applications such as workstations, machine tools, wire drawing machines, annealing furnaces, control racks, and other technical installations.

For each application, **SRS develops tailor-made solutions** designed to meet specific technical, functional, and aesthetic requirements, ensuring reliability and seamless integration with the customer's project.

CERTIFICATIONS AND TECHNICAL SUPPORT



We provide **technical documentation,** product data sheets, and quality certifications to support designers, engineers, and field operators throughout every stage of the project.

Our technical team is available to assist with **product selection, integration, and installation,** ensuring that SRS roller shutters and components meet the specific requirements of each application.



HOW TO CHOOSE YOUR ROLLER SHUTTER

1. ROLLER SHUTTER WITH WINDING ROLL OR SLIDING SYSTEM

A) Roller Shutter with winding roll

The roller shutter with winding roll wraps around an upper roll when opened. This solution is recommended when:

- The compartment opening is medium or large
- There is sufficient space above the opening for the winding roll
- A robust and versatile solution is required
- The shutter needs to be opened frequently

Main advantages:

- Suitable for large openings
- Highly reliable and well-proven system
- Fast and smooth opening

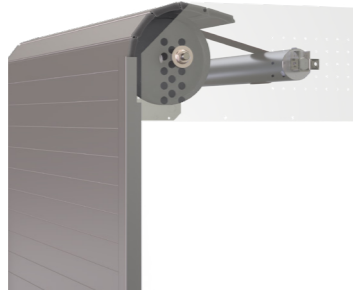

Recommended for any surface size, especially for larger compartments.

B) ECO Sliding Roller Shutter

The ECO sliding roller shutter does not wind around a roll. Instead, it slides inside the compartment and is stored under the roof of the compartment. When fully opened, the shutter remains flat under the roof, while any excess length moves vertically down towards the bottom of the compartment.

This solution is recommended when:

- The compartment opening is small or medium
- Reduced space above the opening is required
- Compact vehicle layouts are being designed

Main advantages:

- Minimal upper space requirement
- Clean and compact design
- Generally lower cost
- Simple installation

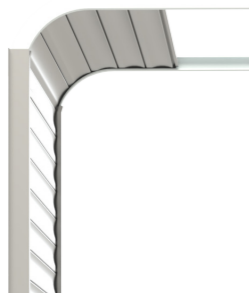

Recommended for surfaces up to approximately 1–1.5 m².

2. ALUMINIUM PROFILES & FINISHING

SRS roller shutters are manufactured using high-quality extruded aluminium profiles specifically designed to ensure strength, durability, and smooth operation.

The available profile heights are H30, H35, and H38, allowing the system to adapt to different installation requirements. The H38 profile is the most widely used, as its optimized geometry provides an excellent strength-to-weight ratio and a lower weight per m², making it particularly suitable for larger shutters.

All profiles are produced from premium extruded aluminium with a carefully engineered cross-section to guarantee high mechanical performance and long-term reliability.

Standard finishes include:

- Satin silver anodized aluminium
- RAL 7035 powder coating



These finishes provide excellent corrosion resistance, durability, and a clean technical appearance, even in demanding operating environments.

Upon request, powder coating can be supplied in over 150 RAL colors to meet specific aesthetic or application requirements.

3. GUIDE PROFILES

Seven different types of guide profiles are available, each optimized according to the specific SRS roller shutter model. Each guide profile is designed to ensure:

- Smooth and reliable sliding
- Optimal sealing, with one or two rubber gaskets
- Full compatibility with dedicated accessories and locking systems

This variety of guide profiles allows the SRS products to adapt to different installation requirements while maintaining high performance and durability.

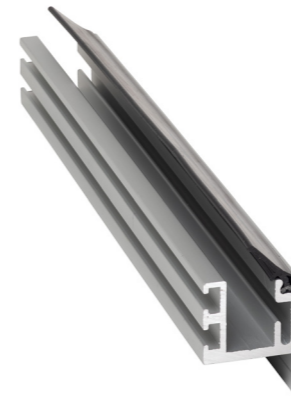

4. CLOSING SYSTEMS

SRS roller shutters are fitted with carefully engineered closing systems, selected according to the shutter model to ensure optimal performance and reliability.

Available with or without a key, these closing systems are constructed from high-strength extruded aluminium, combined with precision metal and technical plastic components. This combination provides an excellent balance of robustness, durability, and long operational life.

All closing systems feature an automatic locking function, which securely locks the shutter when fully lowered, enhancing both ease of use and overall safety.

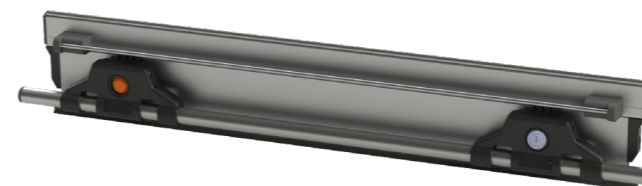

5. OPTIONAL COMPONENTS & ACCESSORIES

To meet different operational and installation requirements, the SRS TOP roller shutter system can be equipped with a wide range of optional components and accessories, including:

- Manual or electric locking systems
- Integrated LED lighting systems
- Magnetic sensors for precise opening and closing detection
- Custom branding, with customer logo application directly on the shutter
- Special sealing kits, featuring gaskets or brush strips for enhanced protection

These options allow each shutter to be fully tailored to the vehicle layout, operational needs, and aesthetic preferences, ensuring both functionality and style.

GASKETS PROFILE

All SRS shutters are equipped with side, intermediate, and bottom seals—essential elements for ensuring high performance and long service life.

The seals provide excellent protection against water, dust, and air, while also improving thermal and acoustic insulation. In addition, they protect components by reducing vibrations, friction, and wear over time.

The result is a shutter that is more airtight, quieter, reliable, and refined in every detail.

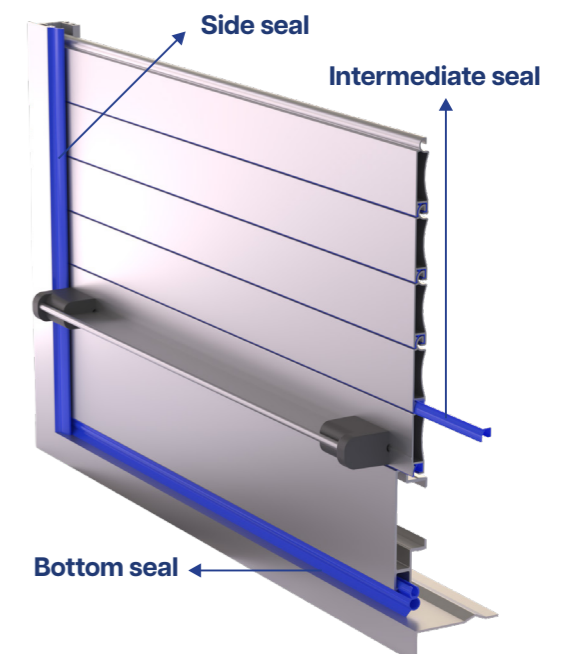

02

SRS TOP

SRS TOP
SRS TOP READY
SRS TOP XL

The **SRS TOP roller shutter** series is designed for installation on a wide range of firefighting, emergency response, industrial, and special-purpose vehicles.

Thanks to a **compact and efficient rolling system**, SRS TOP series shutters provide an ideal alternative to traditional hinged doors, offering **improved accessibility** and optimized use of available space.

These medium-to-large aluminium roller shutters are equipped with a **Ø45 mm** or **Ø60 mm** winding roll, selected according to the shutter dimensions and specific application requirements, ensuring **reliable performance and smooth operation** even in demanding environments.

Order form

SRS TOP - TOP READY - TOP XL



SRS TOP

Versatile, space-saving solutions for emergency, firefighting, and special vehicles.

The **SRS TOP aluminium roller shutter** is assembled using **extruded aluminium profiles H30, H35, or H38**, with customizable height and width to meet specific project requirements. Special configurations are also available on request.

Designed to meet the dimensional and operational needs of vehicle body builders, the system ensures **intuitive assembly and quick installation**, making it particularly suitable for professional vehicle equipment applications.

Each **SRS TOP** roller shutter is supplied in separate components to allow simple and fast on-site assembly:

- 1 pre-assembled shutter complete with closing system (with or without lock), profile with fixing straps for connection to the winding roll
- 1 pair of vertical side guides
- 1 pre-tensioned Ø45 mm winding roll
- 1 accessory kit with mounting screws and hardware
- Additional options available on request

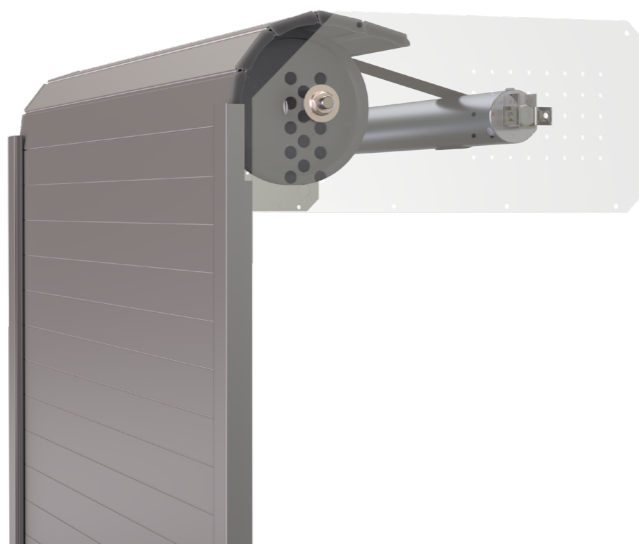

RECOMMENDED DIMENSIONS

2200 mm
MAX. WIDTH

2200 mm
MAX. HEIGHT

4,5 mm²
MAX. SURFACE AREA

SHUTTER WEIGHT FOR m²

(based on profile type):

14 Kg (approx.)
H30 PROFILE

13 Kg (approx.)
H35 PROFILE

12 Kg (approx.)
H38 PROFILE



SRS TOP READY

Pre-assembled solution for fast and efficient installation

The **SRS TOP READY** model is a **fully pre-assembled aluminium roller shutter**, designed for installation in the main compartments of emergency, special-purpose, and industrial vehicles.

It provides a **compact and highly functional alternative** to traditional hinged doors, particularly suitable for applications where fast access and space optimization are essential.

Manufactured using high-quality extruded aluminum profiles (**H30** or **H38**), each shutter is custom-built according to the compartment height and the specific application requirements of the customer, ensuring **perfect integration with the vehicle structure**.

Each **SRS TOP READY** roller shutter is delivered as a fully pre-assembled kit, ready for installation, and includes:

- 1 pre-assembled roller shutter integrated into the kit and complete with:
 - 1 Closing system (with or without key)
 - 1 Ø45 mm pre-tensioned winding roll, mounted to the shutter
 - 2 fixing plates assembled with 3 corner brackets forming the structural frame of the kit
 - 2 sets of sliding wheels, pre-installed within the kit
 - 1 pair of vertical side guides
- 1 box containing mounting accessories and fastening hardware
- Additional options available on request



RECOMMENDED DIMENSIONS

2200 mm

MAX. WIDTH

1900 mm

MAX. HEIGHT

4 mm²

MAX. SURFACE AREA



SRS TOP XL

Robust and heavy-duty solution for large compartments

The **SRS TOP XL** model is specifically designed for **large compartment openings**, providing a reinforced structure and high performance.

Ideal for commercial and logistic vehicles, it represents a reliable and functional alternative to traditional hinged doors, particularly for applications with openings of up to 7 m².

Equipped with an oversized Ø60 mm winding roll and closing system, the SRS TOP XL model ensures **smooth operation, long-term durability**, and **superior structural stability**, even in demanding working conditions.

The **SRS TOP XL** aluminium roller shutter is manufactured using high-strength extruded aluminium H38 profiles, and is custom-built according to the compartment dimensions and the specific technical requirements of the customer.

Each **SRS TOP XL** roller shutter is supplied in separate components to allow simple and fast on-site assembly:

- 1 pre-assembled shutter complete with closing system (with or without lock), profile with fixing straps for connection to the winding roll
- 1 pair of vertical side guides
- 1 pre-tensioned Ø60 mm winding roll
- 1 accessory kit with mounting screws and hardware
- Additional options available on request

This configuration allows for **efficient on-site assembly** and **seamless integration** into large vehicle compartments.

RECOMMENDED DIMENSIONS

2900 mm

MAX. WIDTH

2500 mm

MAX. HEIGHT

1000 mm

MIN. WIDTH

7 m²

MAX. RECOMMENDED SURFACE AREA

H38 **12** kg/m²

WEIGHT: SAME AS STANDARD TOP MODEL

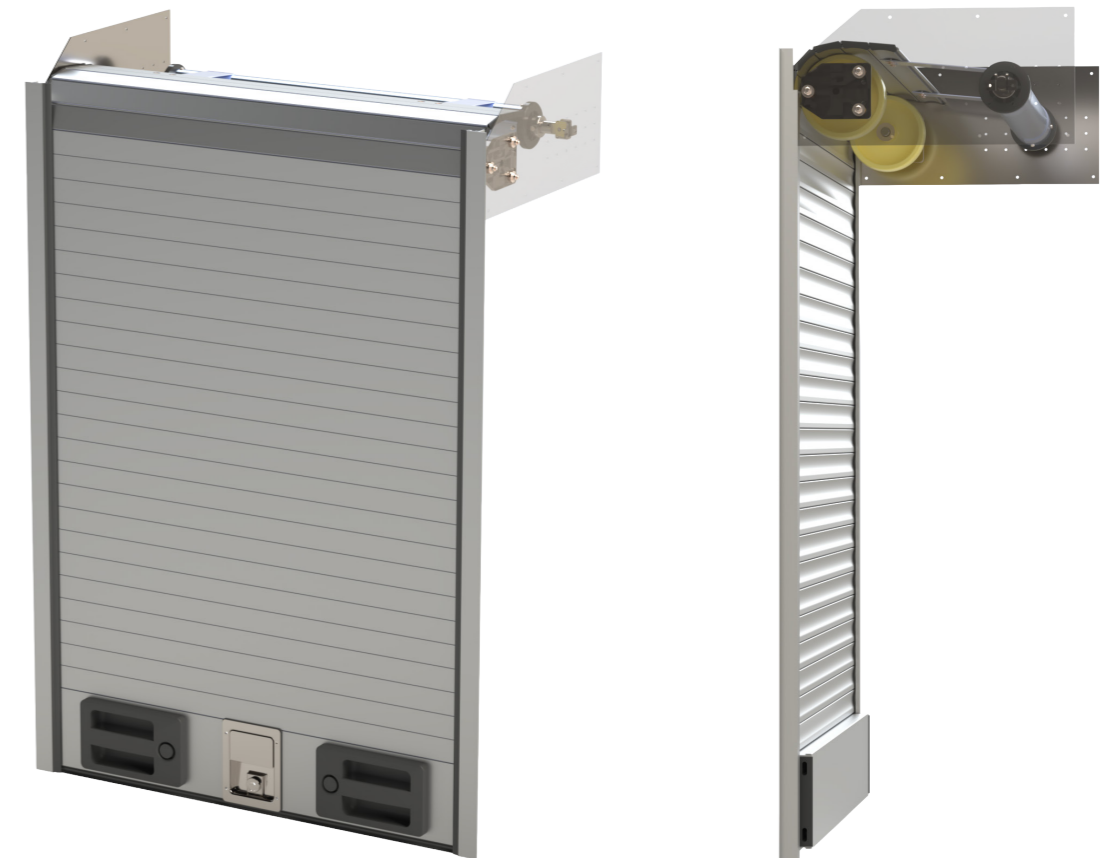
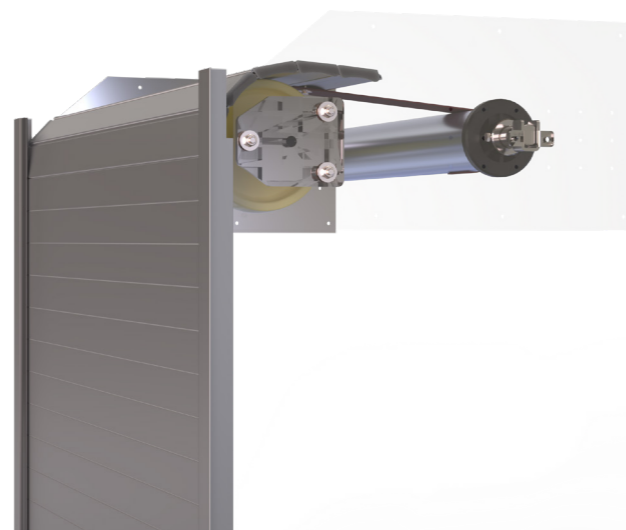

03

SRS TOP-E

SRS *TOP -E* STANDARD
SERENA MOTOR

SRS *TOP -E* TUBULAR
MOTOR

Electric roller shutter designed for **enhanced operator convenience.**

Custom-built using extruded aluminium H38 profiles, the TOP-E series combines technical design with **advanced functionality.**

Ideal for special vehicle applications, it is equipped with a compact, low-power electric motor, available in Standard SERENA or Tubular motor versions (12V, 24V, or 230V).

The **TOP-E system offers maximum versatility**, reliable performance, and reduced installation space, making it particularly suitable for vehicle compartments where efficiency and ease of operation are essential.

An electric solution specifically designed to **simplify the operator's work**, ensuring **fast and effortless opening and closing operations.**

Order form
SRS TOP E



SRS TOP-E

SRS TOP-E “STANDARD SERENA MOTOR”

The **TOP -E** roller shutter with **STANDARD SERENA MOTOR**, featuring the H38 profile, is designed for large openings and special applications.

The STANDARD SERENA MOTOR is designed to deliver **powerful and reliable operation** for roller shutter systems requiring higher torque and durability.

Its robust mechanical construction ensures **long service life** and dependable performance in demanding professional environments.

Key Features

- High torque output
- Gear reduction transmission
- Strong and durable construction
- Suitable for intensive use
- Easy access for maintenance

Applications

Industrial shutters, heavy-duty installations, and professional equipment.

Standard Serena motor Specifications

- 12V: 20 Nm / 12 rpm – Lifting capacity: **70 kg** with emergency system
- 24V: 20 Nm / 12 rpm – Lifting capacity: **70 kg** with emergency system

Each **SRS TOP -E** roller shutter is supplied in separate components to allow simple and fast on-site assembly:

- 1 pre-assembled shutter complete with closing system (without lock), profile with fixing straps for connection to the winding roll
- 1 pair of vertical side guides
- 1 pre-tensioned Ø45 mm winding roll
- 1 box with motor,
- 1 accessory kit with mounting screws and hardware
- Additional options available on request

RECOMMENDED DIMENSIONS

2000 mm

MAX. WIDTH

2500 mm

MAX. HEIGHT

5 m²

MAX. RECOMMENDED SURFACE AREA



	12v No Radio	24v No Radio
Lifting capacity @20Nm	70Kg	70Kg
Emergency system	Yes	Yes
Remote control	No	No

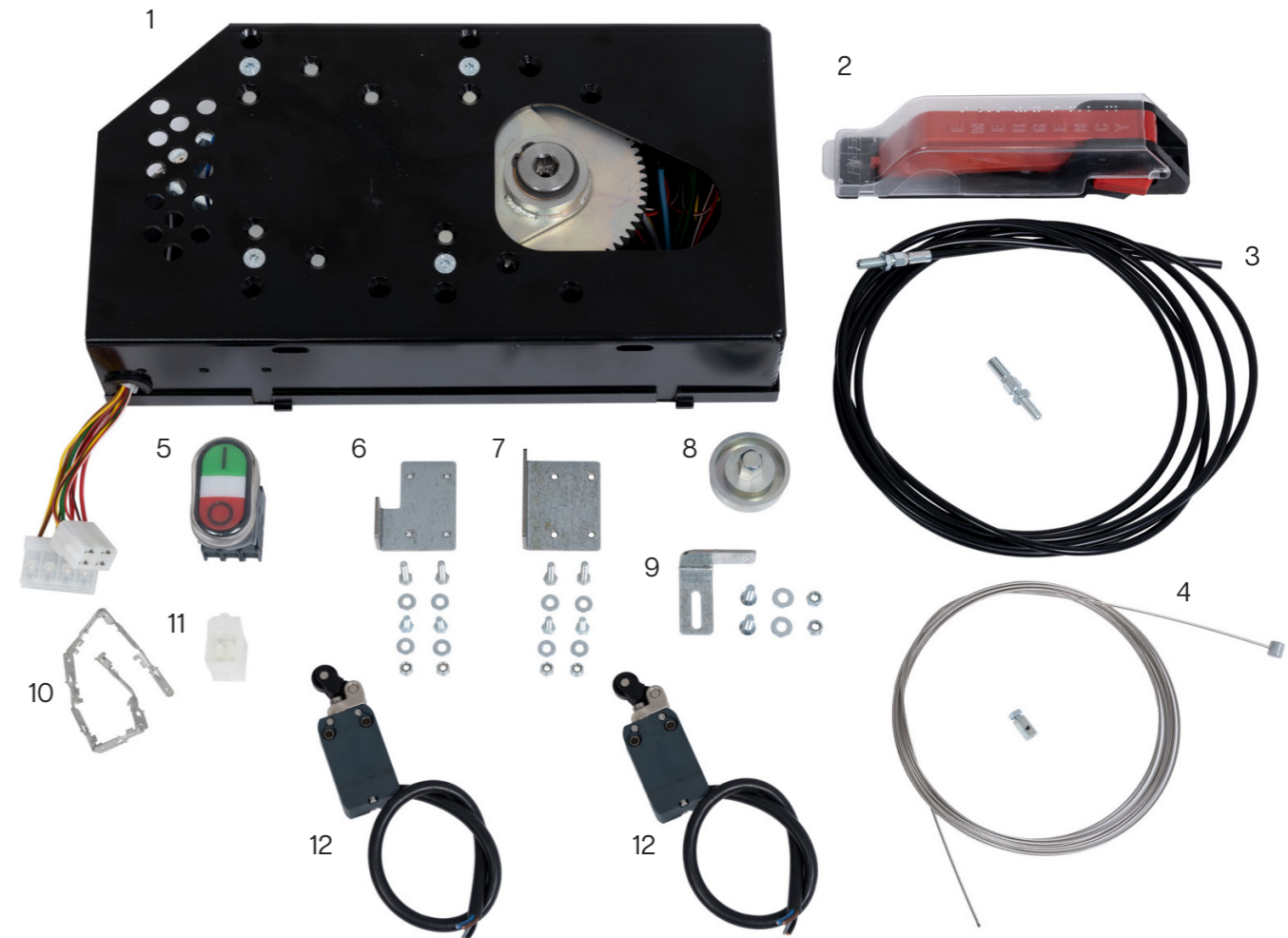

1	Motor + carter	5	Button	9	Microswitch lever drive
2	Handle release	6	Upper microswitch support	10	PIN
3	Cable release	7	Lower microswitch support	11	Connector
4	Membrane	8	Roller cap with hexagonal pin	12	Microswitch



SRS TOP-E “TUBULAR MOTOR”

The **TOP -E** roller shutter with **TUBULAR MOTOR**, featuring the H38 profile, is designed for special applications

The TUBULAR MOTOR is a compact and reliable solution for the automation of roller shutters installed on vehicles and professional equipment. Designed to be integrated inside the winding roll, it ensures a **space-saving installation** while maintaining high operational efficiency.

Its quiet operation and protected internal structure guarantee **smooth and consistent movement** even under frequent use. The integrated adjustable limit switch system allows **precise control of opening and closing positions**, improving safety and durability.

Key Features

- Compact integrated design
- Easy installation inside the roller tube
- Quiet and smooth operation
- Adjustable limit switch system
- Reliable performance over time

Applications

Service vehicles, equipped vans, mobile workshops, and professional installations.

Tubular motor specifications

- 12V – 20 Nm / 12 rpm: Lifting capacity: **30 kg** with emergency system
- 24V – 35 Nm / 12 rpm: Lifting capacity: **55 kg** without emergency system
- 230V – 30 / 50 / 80 / 100 / 120 Nm / 12 rpm: Capacity: 56/ 95/ 120 / 150 / 180 kg –with or without emergency system and remote control

Standard Serena motor Specifications

Each **SRS TOP -E** roller shutter is supplied in separate components to allow simple and fast on-site assembly:

- 1 pre-assembled shutter complete with closing system (without lock), profile with fixing straps for connection to the winding roll
- 1 pair of vertical side guides
- 1 winding roll
- 1 box with motor, + 1 accessory kit with mounting screws and hardware
- Additional options available on request

RECOMMENDED DIMENSIONS

3000 mm

MAX. WIDTH

2800 mm

MAX. HEIGHT

8 m²

MAX. RECOMMENDED SURFACE AREA

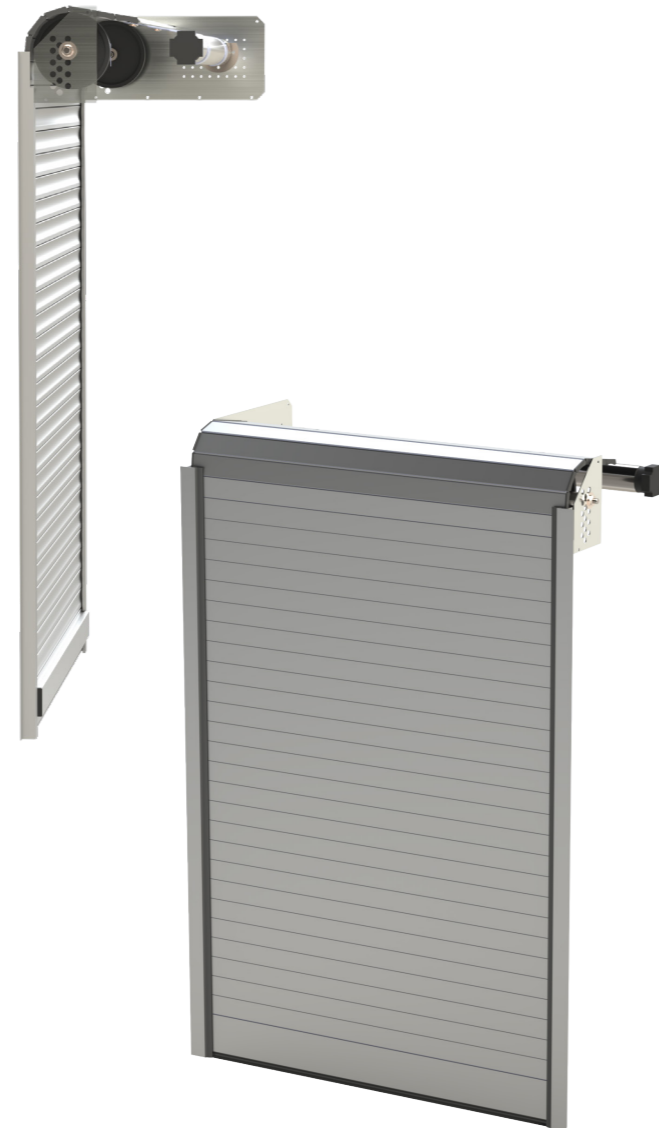

	12v	24v
Lifting capacity @20Nm	30Kg	n.a.
Lifting capacity @35Nm	n.a.	55Kg
Emergency system	Yes	No

	12v No Radio	24v No Radio
Lifting capacity @30/50/80/100Nm	56/96/120/150Kg	56/96/120/150Kg
Emergency system	Yes	Yes
Wireless remote control + cover	No	Yes
Selector with key	Yes	No
Button	Yes	No

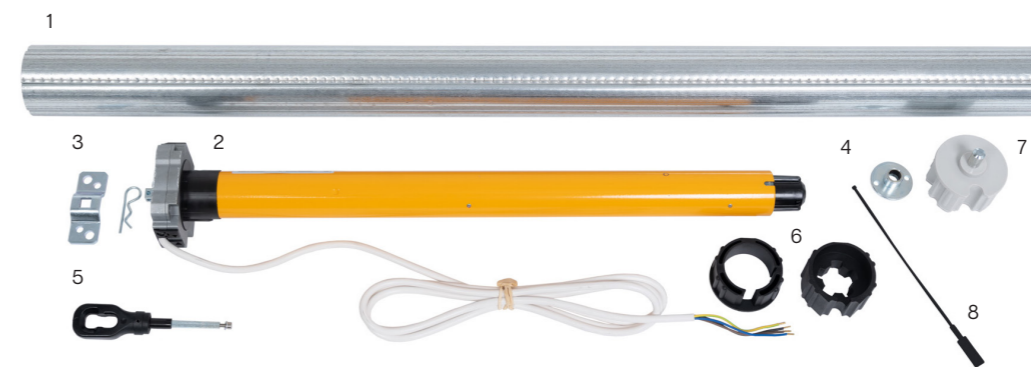

1	Zinc coated roll
2	Motor
3	Right roll support
4	Left roll support
5	Buttonhole
6	Adapters
7	Cap
8	PIN

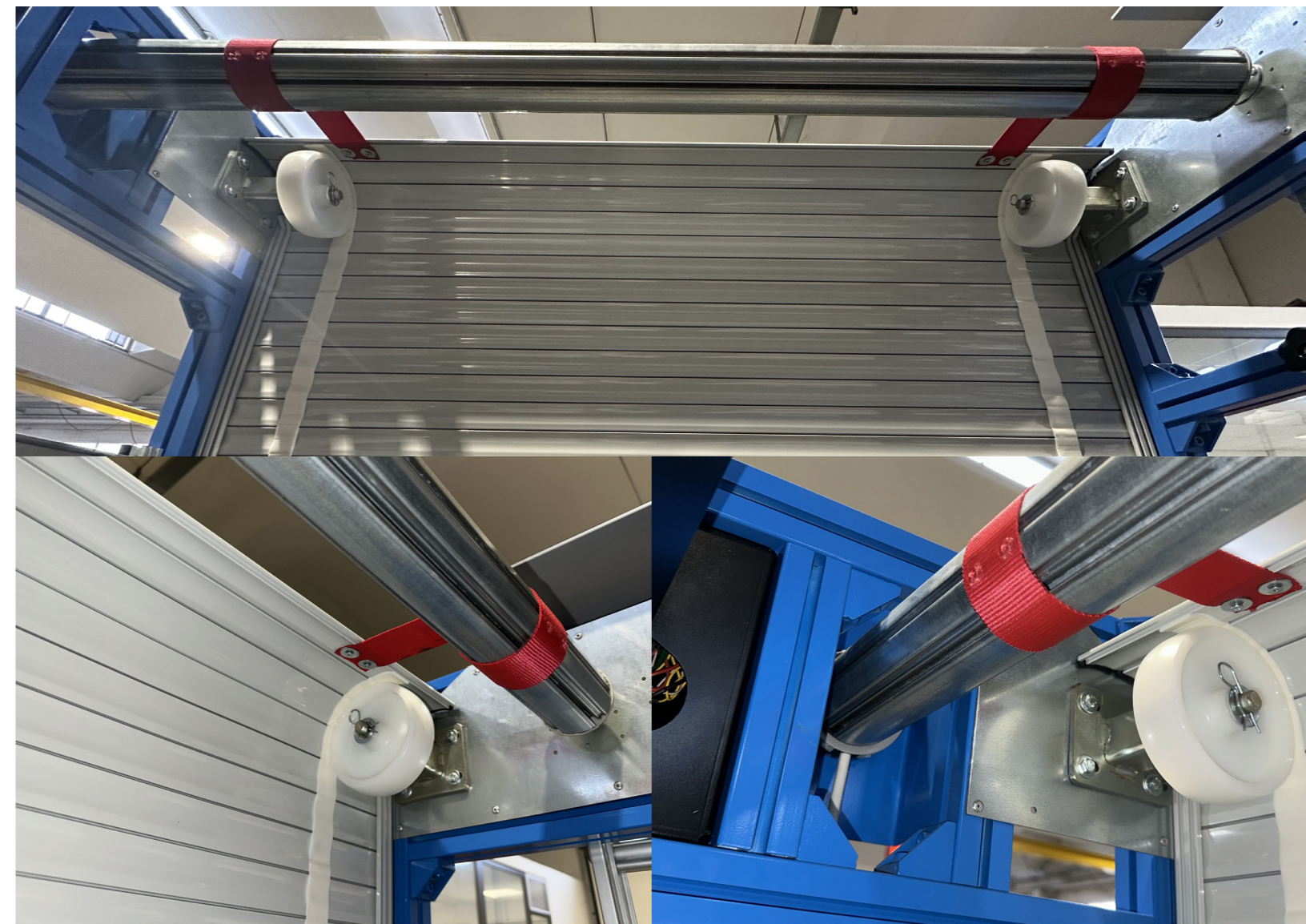

04

SRS ECO

SRS *ECO*
SRS *ECO PLUS*
SRS *ECO SIMPLY*
SRS *ECO PLUS SIMPLY*

Order form

SRS ECO - ECO PLUS



Order form

SRS ECO SIMPLY - ECO PLUS SIMPLY



Compact roller shutters for small – medium sized openings

The **SRS ECO** and **SRS ECO PLUS** aluminium roller shutters are constructed using H30 or H38 profiles and are custom-made to the required height using extruded components with specific technical features. Designed for small-medium sized compartments, they are an **excellent alternative to bulky swing doors**.



SRS ECO

The **SRS ECO** shutter system features a sliding mechanism that **optimizes space usage** inside the vehicle. When opened, the shutter lies flat horizontally beneath the roof, with any excess length positioned vertically at the rear.

This system is ideal for areas up to 1 m². It offers a **cost-effective and easy-to-install solution** while maintaining the reliability and sleek design typical of all SRS shutters.

Each **SRS ECO** shutter is supplied in separate components to allow simple and fast on-site assembly:

- 1 pre-assembled shutter, complete with closing system (with or without lock)
- 1 pair of vertical side guides
- 1 pair of aluminium curves, available in standard size 300 × 300 mm
- 2 sliding extensions, when required, in different lengths depending on the depth
- 1 accessories box
- Additional options available on request

MAXIMUM RECOMMENDED AREA

1 m²



SRS ECO PLUS

The **SRS ECO PLUS** includes a special Ø45 wrapping roll, pre-configured to match the dimensions of the shutter, along with dedicated guide rails similar to the SRS ECO model.

Once opened, the shutter lays flat under the roof, with any surplus length positioned vertically at the rear. Suitable for openings up to 1.5 m², the SRS ECO PLUS model is characterized by its **reliability**, high-quality construction, and refined design.

Each **SRS ECO PLUS** roller shutter is supplied in separate components to allow simple and fast on-site assembly:

- 1 pre-assembled shutter complete with closing system (with or without lock), profile with fixing straps for connection to the winding roll
- 1 pair of vertical side guides
- 1 pre-tensioned Ø45 mm winding roll
- 1 pairs of aluminium curves, available in standard size 300 × 300 mm
- 2 sliding extensions, when required, in different lengths depending on the depth
- 1 accessories box
- Additional options available on request

MAXIMUM RECOMMENDED AREA

1,5 m²



SRS ECO SIMPLY

The **SRS ECO SIMPLY** shutter system features a sliding mechanism that **optimizes space usage** inside the vehicle. When opened, the shutter lies flat horizontally beneath the roof, with any excess length positioned vertically at the rear.

This system is ideal for areas up to 1 m². It offers a **cost-effective and easy-to-install solution** while maintaining the reliability and sleek design typical of all SRS shutters.

Each **SRS ECO SIMPLY** shutter is supplied in separate components to allow simple and fast on-site assembly:

The system is supplied as an assembly kit to facilitate transport and installation:

- 1 pre-assembled shutter, complete with bottom closing rail (with or without lock)
- 1 pair of SIMPLY vertical side guides
- 1 pair of plastic SIMPLY curves, available in standard size 90 × 185 mm
- 2 sliding extensions, when required, in different lengths depending on the depth
- 1 accessories box
- Additional options available on request

MAXIMUM RECOMMENDED AREA

1 m²



SRS ECO PLUS SIMPLY

The **SRS ECO PLUS SIMPLY** includes a special **Ø45** winding roll, pre-configured to match the dimensions of the shutter, along with dedicated guide rails similar to the SRS ECO SIMPLY model.

Once opened, the shutter lays flat under the roof, with any surplus length positioned vertically at the rear. Suitable for openings up to **1.5 m²**, the SRS ECO PLUS SIMPLY model is characterized by its **reliability**, high-quality construction, and refined design.

Each **SRS ECO PLUS SIMPLY** roller shutter is supplied in separate components to allow simple and fast on-site assembly:

- 1 pre-assembled shutter complete with closing system (with or without lock), profile with fixing straps for connection to the winding roll
- 1 pair of SIMPLY vertical side guides
- 1 pre-tensioned Ø45 mm winding roll
- 1 pair of plastic SIMPLY curves, available in standard size 90 × 185 mm
- 2 sliding extensions, when required, in different lengths depending on the depth
- 1 accessories box
- Additional options available on request

MAXIMUM RECOMMENDED AREA

1,5 m²



05

CUSTOM MADE

FINISHING
GUIDES
CLOSING SYSTEMS
WINDING ROLLS
ACCESSORIES



FINISHING

Description

Made from **high-quality extruded aluminium**, the profiles used in SRS roller shutters feature an optimized cross-section to ensure **superior mechanical performance**.

Available in standard satin silver anodized finish or RAL 7035 powder coating, both providing **outstanding corrosion resistance and durability over time**. Profile heights range from 30 mm to 38 mm, depending on installation requirements.

Upon request, powder coating can be applied in over 150 RAL colors for **fully customized applications**.

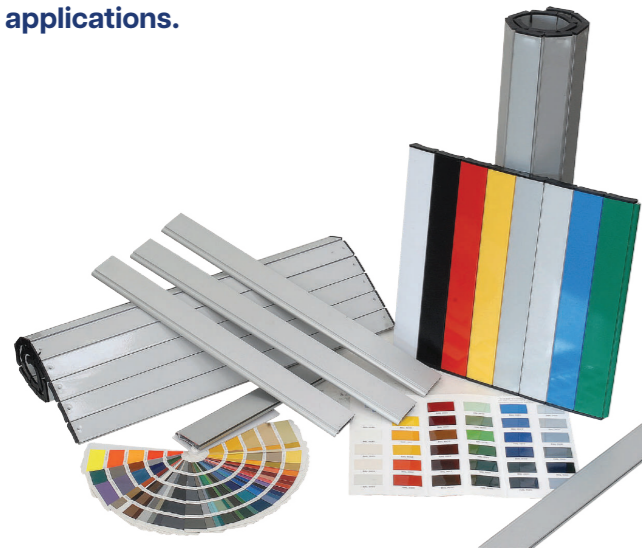

GUIDES

Several guide profiles are available, optimized according to the SRS shutter model

Seven different guide profiles are available, each specifically designed and optimized for the various SRS roller shutter models. Every guide profile is engineered to ensure:

- Smooth and reliable shutter movement
- Optimal sealing, thanks to one or two integrated rubber gaskets
- Full compatibility with dedicated accessories and locking systems

Guide profiles can also be supplied pre-machined, including milled or curved versions, to meet **specific installation or design requirements**.

This wide range of guide profiles allows the SRS system to adapt to different installation configurations while maintaining **high levels of performance, reliability, and durability**.



	MP1	MP2	MP4	MP5	MP6	MP7	SIMPLY
TOP	[Profile diagram]						
TOP READY	[Profile diagram]						
TOP XL	[Profile diagram]						
TOP E	[Profile diagram]						
ECO	[Profile diagram]						
ECO PLUS	[Profile diagram]						
ECO SIMPLY	[Profile diagram]						
ECO PLUS SIMPLY	[Profile diagram]						

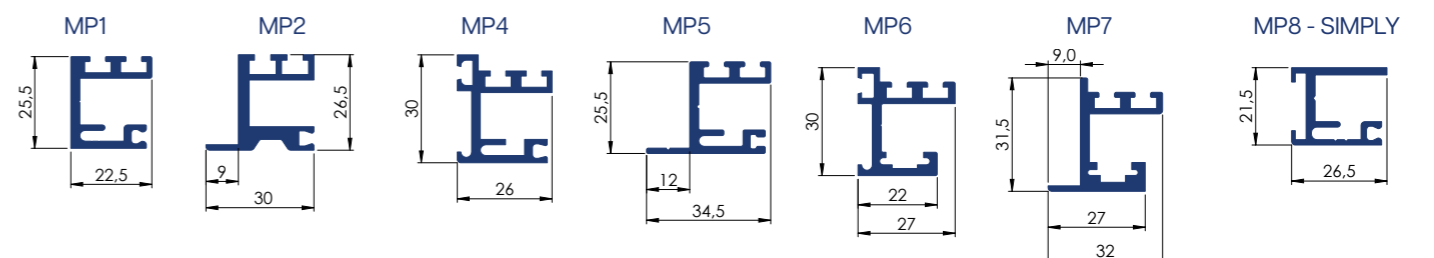

CLOSING SYSTEMS

SRS roller shutters are equipped with a range of locking systems selected according to the shutter model to ensure **optimal performance**.

Available in both key-operated and keyless versions, they are manufactured from high-strength extruded aluminium, combined with metal components and engineered plastics, ensuring an excellent balance of **robustness, reliability, and long service life**.

All systems feature an **automatic locking function**: the shutter securely locks when fully lowered, enhancing ease of use and overall safety.

	T1	T2	T3	T4	T5	T8	T9
TOP	—	—	—	—	—	—	—
TOP READY	—	—	—	—	—	—	—
TOP XL	—	—	—	—	—	—	—
TOP E	—	—	—	—	—	—	—
ECO	—	—	—	—	—	—	—
ECO PLUS	—	—	—	—	—	—	—
ECO SIMPLY	—	—	—	—	—	—	—
ECO PLUS SIMPLY	—	—	—	—	—	—	—

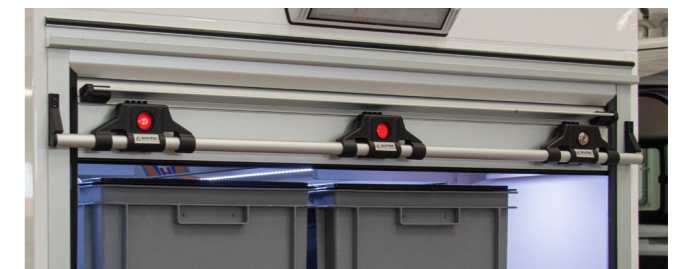
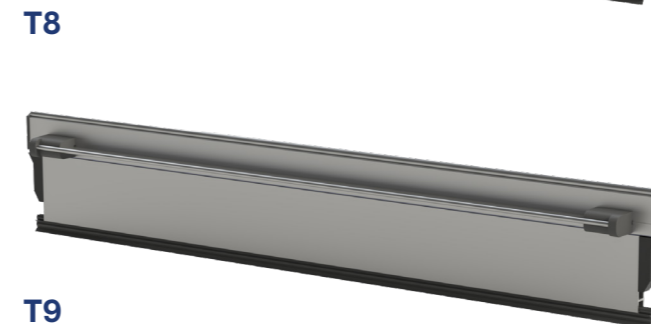
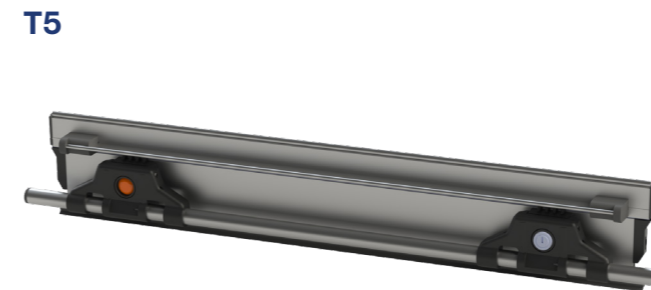

WINDING ROLLS

Aluminium rolls – Ø45 mm and Ø60 mm

Winding rolls are available in Ø45 mm and Ø60 mm diameters, to suit different space, configuration, and load requirements.

Both versions are equipped with **pre-tensioned steel springs**, designed to ensure **high mechanical strength and consistent performance over time**.

The Ø45 mm roll

Typically used for TOP shutters, is among the **most compact solutions available on the market**. It significantly reduces the overall size of the shutter when rolled up, making it ideal for **installations with limited space**.

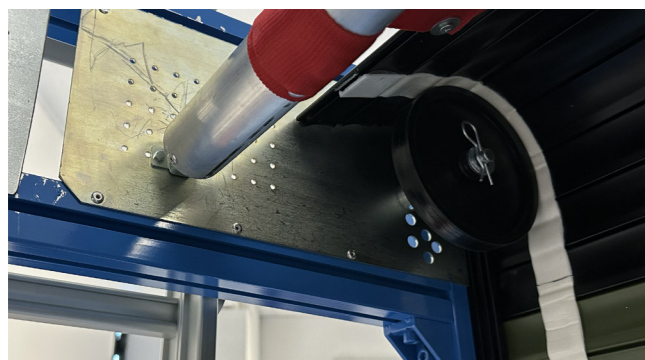
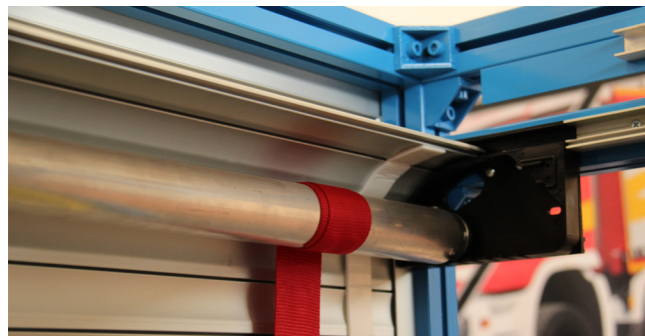

The Ø60 mm roll

Designed for TOP XL shutters with higher weight, ensures **optimal winding performance** even for large dimensions, providing **stability, reliability, and long-lasting operation**.

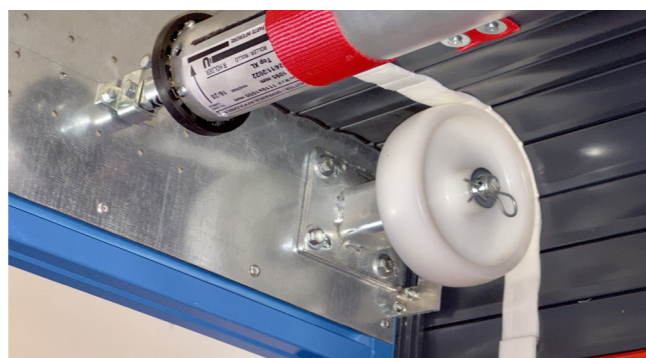
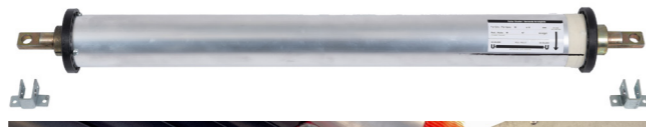

ACCESSORIES

Accessories are a key element in completing and enhancing aluminium roller shutters, improving their **functionality, security, and long-term durability**. This section presents a range of solutions designed to meet a variety of application needs, ensuring **reliability**, ease of use, and seamless integration with every system.

Gutter profiles

Aluminium gutter profiles, available in two sizes, guide the shutter smoothly during operation while **optimising water drainage**. Installed at the top of the compartment, they direct water away from the shutter, preventing leaks and potential damage. The profiles are fixed with screws or rivets in a dedicated groove, hidden by a seal (big gutter profile), **uniform finish**, and are available in different colour options to match the installation.

Big gutter profile

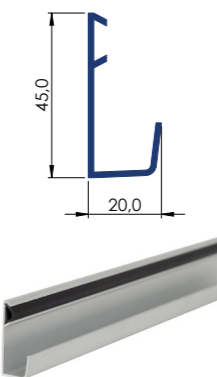

Small gutter profile

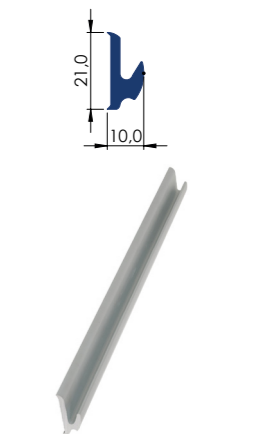

Lower profiles

The aluminium lower profile, available in two sizes, supports the shutter when closed, ensures **proper sealing against dust and water**, protects the bottom edge from wear, and provides a **clean, durable finish**. Available in different colour options.

Big lower profile

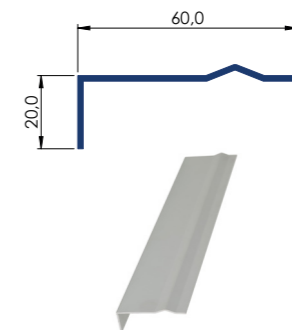

Small lower profile

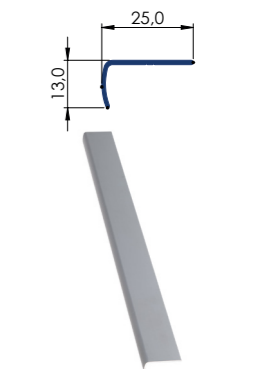

Covers

Protective profiles that protect mechanical components and shutter profiles from **dust, dirt, and moisture**, while providing a **clean, finished appearance** for a durable and tidy installation.

Cover 50x20

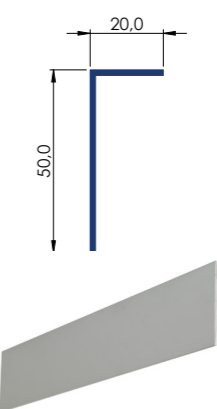

Cover 80x20

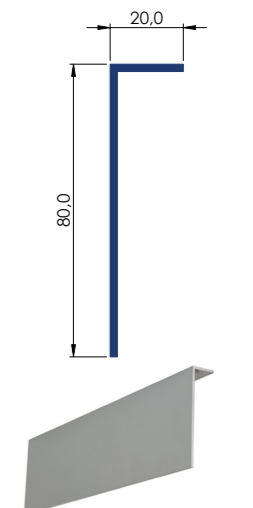

Milled shutter profile with gasket

Milled shutter profile with **integrated gasket**, designed to provide **effective protection against dust, air, and water**.

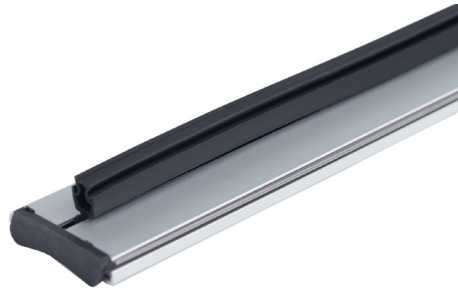

Aluminium profile with brush

Aluminium profile with **integrated brush or rubber gasket**, mounted at the top of the shutter. It cleans dust and debris during operation, ensuring **smooth movement** and protecting the shutter profiles.

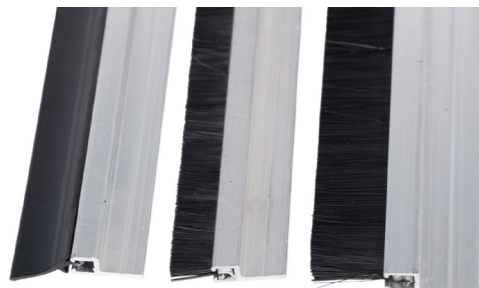

Pulling Belt

The pulling belt, available in standard or elastic versions, is an **essential accessory** for aluminium shutters installed at high elevations. It allows the shutter to be operated without directly reaching the closing system or grip profile, ensuring **safe and convenient closing**.

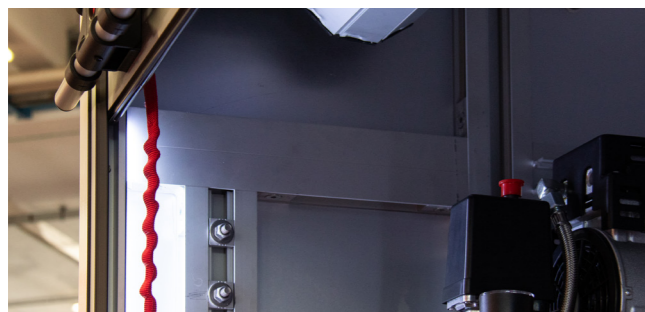

Inside LED

12V or 24V **LED** ideal for installation on the side guides. It provides **uniform illumination with low energy consumption**, enhancing visibility and safety during shutter operation.

Measures	S300	S500	S1000
LED quantity	18	30	60
Body	Aluminium	Aluminium	Aluminium
Lens size	500	500	1000
Lens coated	Silicon	Silicon	Silicon
Color intensity	6000K	6000K	6000K

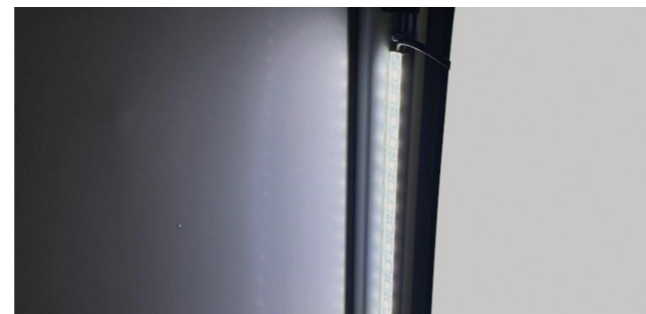

External LED

12v or 24v LED used to illuminate the external and perimeter area. It is supplied in anodized aluminium profile, polycarbonate cover, plastic end caps, mounting clips and rivets.

- **Color intensity:** 6000k ;
- **Operating temperature:** -25°C ~ +40°C ;
- **Max temperature:** 75°C Max
- **Lifetime:** 60,000 h ;
- **IP Rating:** IP65

Dimensions Section: 19 x 19 mm

Max length: 3000 mm

(L 700 mm: Ws < 1000 mm) (L 1000 mm: Ws 1001 – 1299 mm) (L 1300 mm: Ws 1300 – 1600 mm)

Custom sizes available on request

Ws = shutter opening width



Proximity magnetic sensor 612

Proximity magnetic sensor featuring microminiature Reed contacts; the output function can be normally closed (NC) or normally open (NO). A very **compact sensor**, designed with **highly sensitive contacts and low hysteresis**. Available in 12V or 24V.

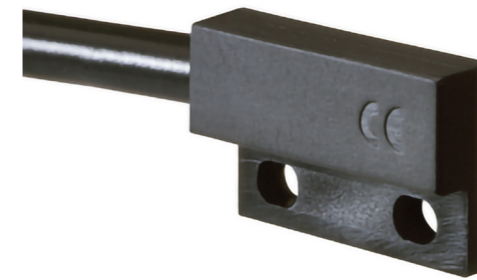

Proximity magnetic sensor

Proximity magnetic sensor with a rectangular plastic housing, featuring a normally closed (NC) output. Available with **high-power** output for direct control and **low-power** output for signal applications, ensuring **reliable and versatile performance** across different uses. Available in 12V or 24V.



Electric Locking System 12/24 V

System designed to **automatically lock and unlock roller shutters** without the need for a manual key, featuring electrical control and vehicle integration.

Functions

- Electric locking and unlocking
- Automatic hold in open position
- Control via remote transmitter or RFID technology
- Integration with vehicle central locking system
- Status indication via LED

Available Versions

Horizontal Kit

- 5-wire actuator 12/24V
- Central mounting bracket + cross bar (only on upper part)
- Dedicated shutter profile
- Recommended for shutters up to 1200 mm width



Vertical Side Kit

- 5-wire actuator 12/24V
- Side bracket (RH or LH)
- Dedicated shutter profile
- Recommended for shutters over 1200 mm (double kit suggested)



Control

- Control unit with 1 or 2 TXSP4 remote transmitters
- Control unit with RFID touch control (complete wiring included)



Installation

- Mounting on cross bar (horizontal) or side guide (vertical)
- Side drilling required during installation (horizontal kit)

06

OTHER ARTICLES

- LADDERS
- SLIDES
- DRAWERS
- LOCKING SYSTEMS
- HOSE DIVIDERS
- HANDRAILS
- BOXES

A wide range of accessories are available, designed to complete and optimize the performance of our shutters. Each component is made from high-quality materials and can be customized according to the specific requirements of the installation.

LADDERS

Elevate26 Ladder – Excellence for Fire fighting and Rescue Vehicles

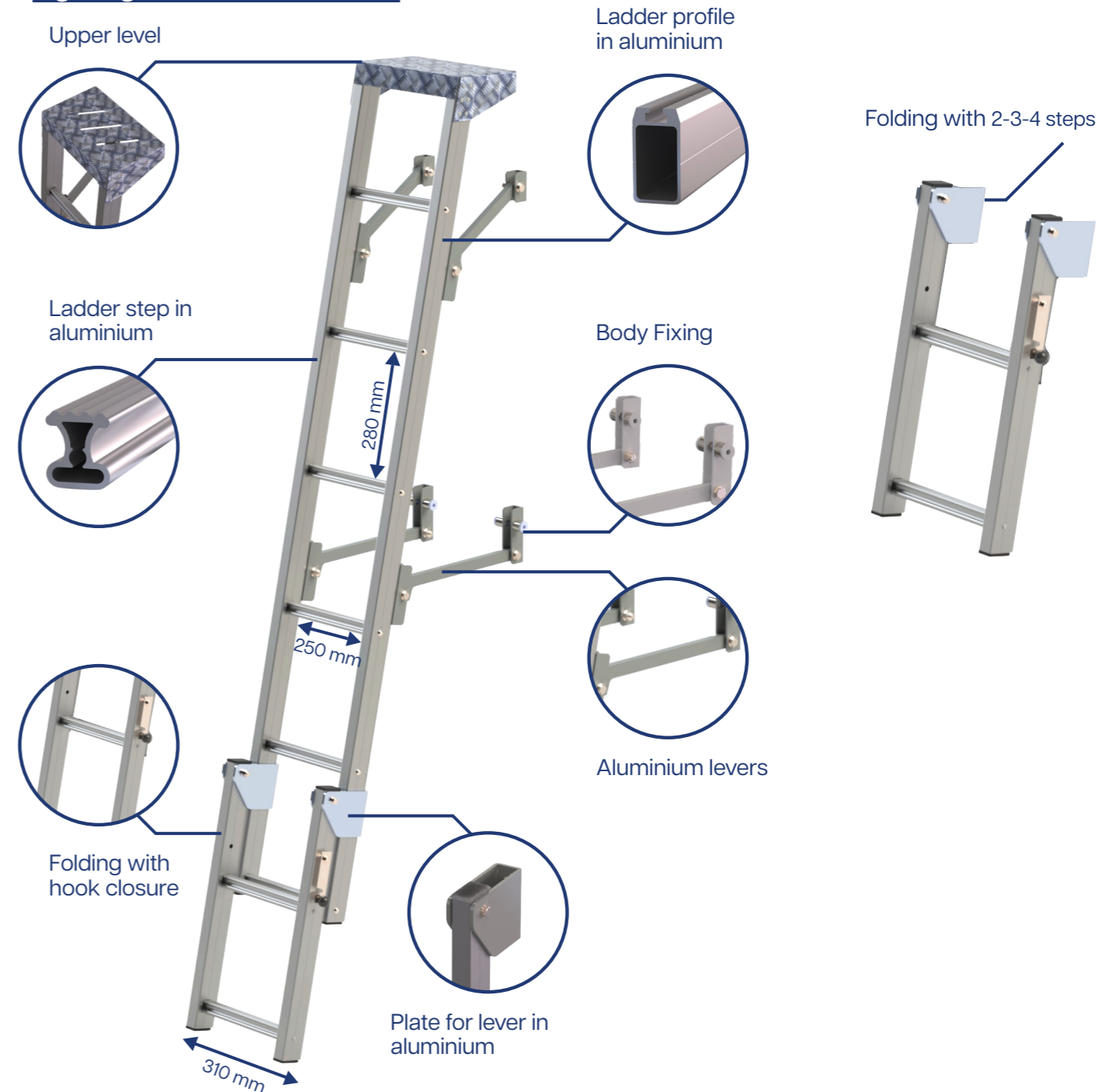

TECHNICAL FEATURES

Profile	Aluminium alloy EN-AW 6060	Upper level	310 x 180 mm, ribbed aluminium
Steps	280 mm	Colour	Silver anodized
Total width	310 mm	Max payload	150 kg

INCLINED UP & DOWN LADDER



TECHNICAL FEATURES			
Profile	Aluminium alloy EN-AW 6060	Upper level	322 x 180 mm, ribbed aluminium
Steps	303 mm	Colour	Silver anodized
Total width	322 mm	Max payload	120 kg

FIXED LADDER

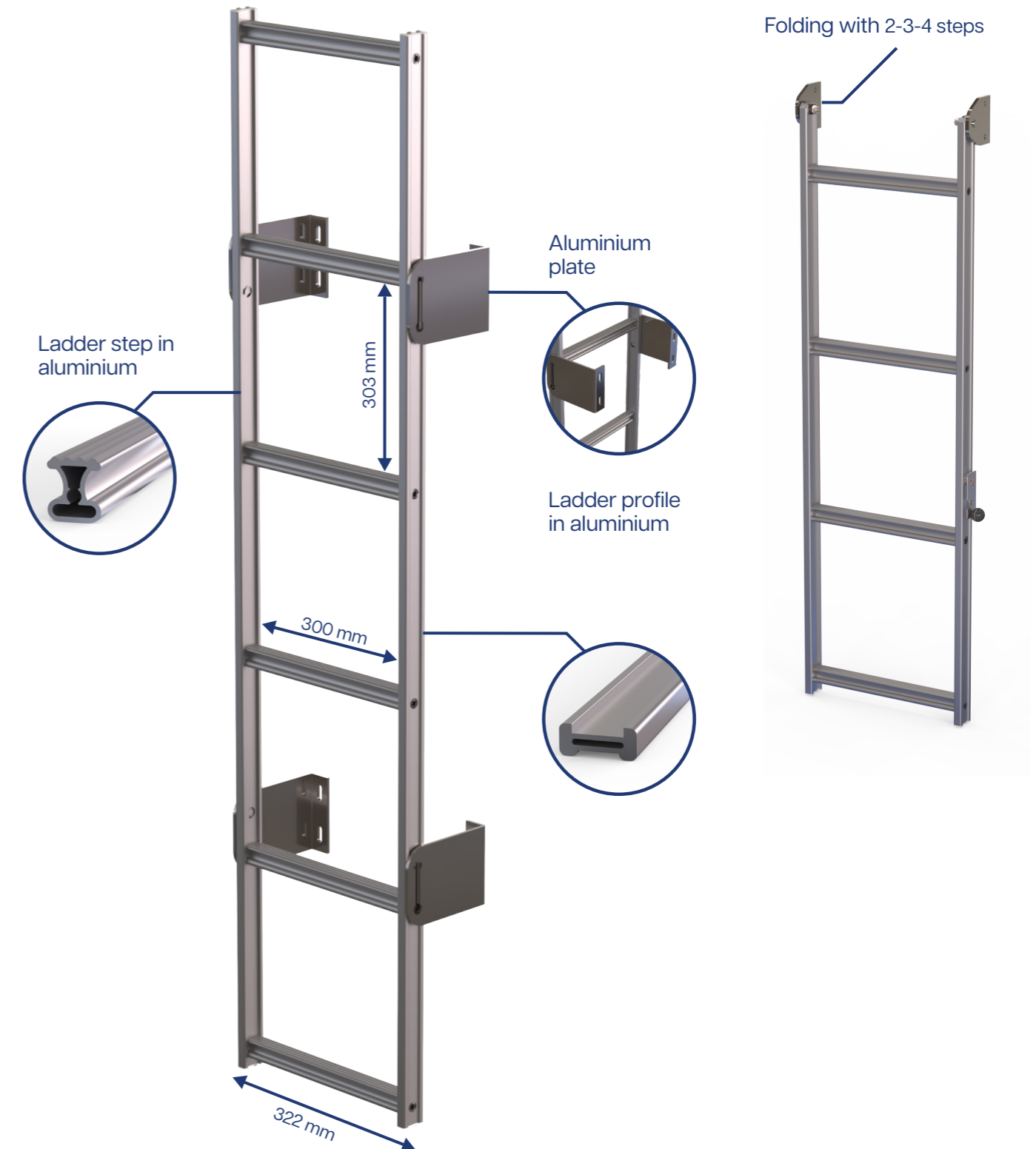

TECHNICAL FEATURES			
Profile	Aluminium alloy EN-AW 6060	Upper level	Without upper level
Steps	303 mm	Colour	Silver anodized
Width	322 mm	Max payload	120 kg

SLIDES

The SRS extractable slides are designed for **maximum durability and functionality**, with a robust galvanized steel construction suitable for a wide range of professional applications. Available in multiple sizes and extraction configurations to meet operational requirements.

Applications

SRS slides can be used for:

- Cylinder holders
- Fire extinguisher holders
- Generator supports
- Pump holders
- SCBA (self-contained breathing apparatus) holders
- Welding equipment holders for doors
- Compressor holders
- General equipment and material storage

Available Sizes

Standard stock sizes:

- **700x470 mm** – full extension
- **750x540 mm** – full extension
- **410x850 mm** – with or without 6-position bracket, full or partial extraction
- **410x540 mm** – with or without 4-position bracket, full extraction

Dimensions refer to the support plate (first value indicating the handle side).

Customization

Custom slides can be produced to meet **specific customer requirements**.

All models are available with **pre-mounted brackets or as standalone plates**, depending on application.

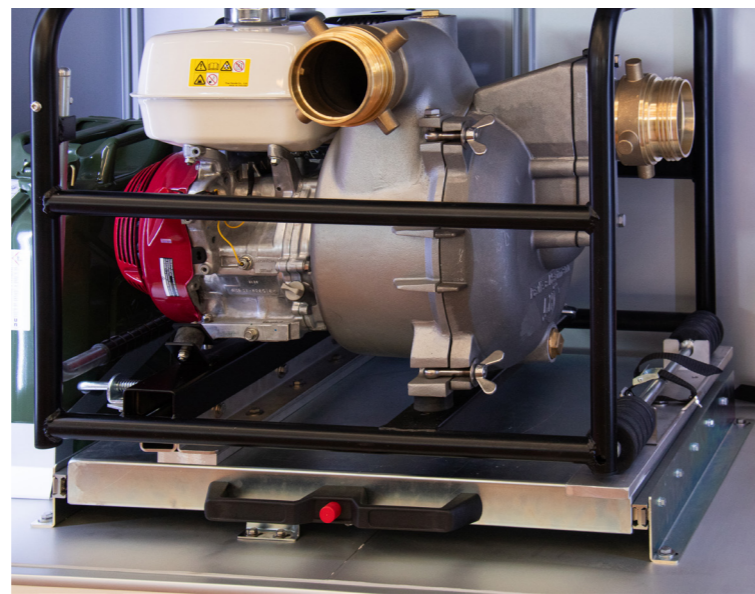
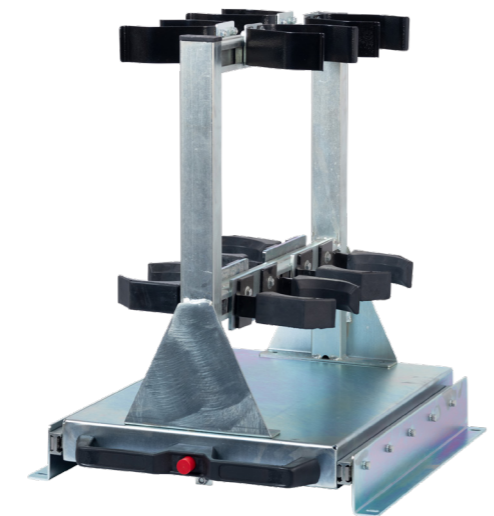
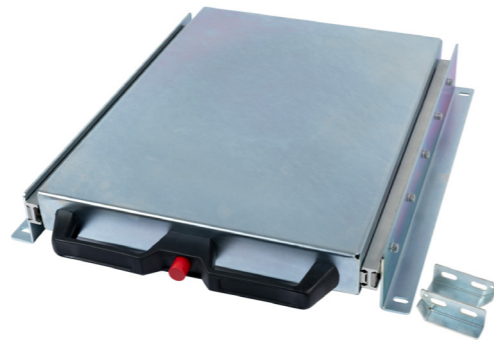
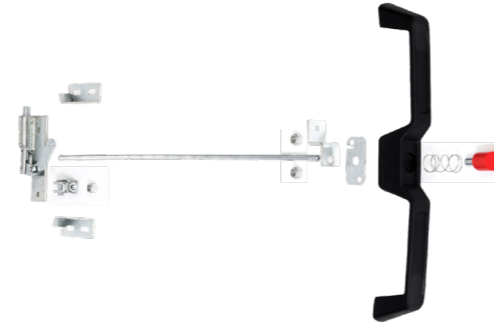

DRAWERS

The ribbed extruded drawers are made of **silver anodized aluminium profiles** with an almond-patterned aluminium bottom, and feature a **double-grip handle locking system**, available with or without key.

Each drawer is custom-made, allowing customers to choose width and depth, while the profile height remains fixed at 120 mm.

Available Sizes:

Width: **600 – 1500 mm**

Depth: **450 – 1000 mm**

Height: **120 mm** (fixed)

The drawers can be mounted on standard sliding systems or supplied with our tilting and sliding extraction system, which includes:

- Galvanized steel guides with polypropylene (PPL) strips for smooth sliding and proper weight distribution
- Nylon wheels and runners for stability and precise movement
- Full extraction and secure hooking at the end of the travel
- Safe tilting onto the top or shelf of the internal compartment for easy access and handling

This system ensures **smooth operation, precise positioning, and reliable load support**, even with heavy contents.

Customization

Drawers can be tailored to specific dimensions and integrated with accessories for a **versatile and durable storage solution**.



LOCKING SYSTEMS

SRS locking systems provide a **reliable and efficient solution** for doors and drawers in special vehicles, industrial fittings, and mobile units.

Available with or without key, each kit includes a **double-grip handle**, internal locking mechanism, and high-strength galvanized steel components.

Designed for **smooth operation and maximum safety**, these systems are compatible with all major opening solutions and can be supplied with red or black push-button, according to customer requirements.

DRAWER KIT WITH KEY

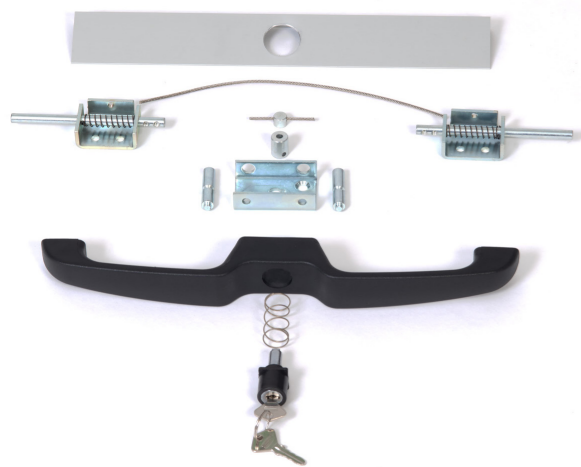

DRAWER KIT WITH BLACK OR RED BUTTON

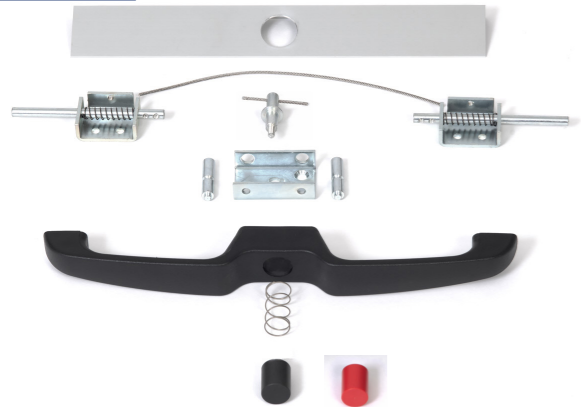

LOCKING KIT WITH KEY



LOCKING KIT WITH RED BUTTON

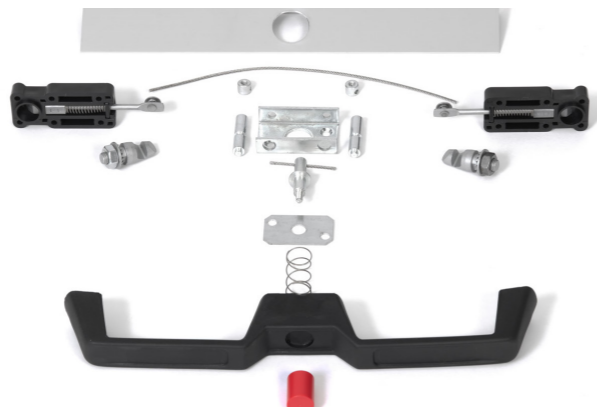

LOCKING KIT WITH BLACK BUTTON



HOSE DIVIDERS - HANDRAILS

Hose dividers

SRS hose dividers are designed to ensure **safe and organized hose storage** on board vehicles, improving accessibility and operational efficiency.

Available in two sizes:

- 465 x 500 mm
- 510 x 550 mm (on request)

They can be customized in the number and size of compartments, depending on the type of couplings installed.

Manufactured from **high-quality, durable materials**, they ensure long-lasting performance and ease of use, even in demanding operating conditions.

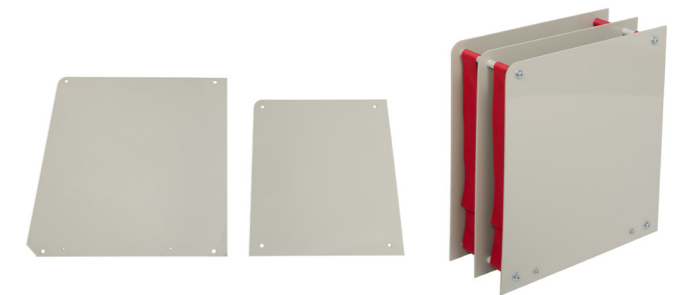

Handrails

SRS handrails are designed to complete vehicle fittings, providing **safety, ergonomics, and a clean, professional design**.

They can be custom-made according to customer specifications, with flexible configurations in length, height, and mounting type.

Manufactured from **anodized aluminium with high-strength technical supports**, they ensure stability, lightweight construction, and long-term durability.



BOXES

Serena Production can supply not only the shutter with its related accessories, but also the **complete box, ready for use** and perfectly optimized in every component.

Each solution is **custom-designed** and can be manufactured in different types of materials, with raw finishes or powder-coated in customized RAL colors, according to specific customer requirements:

- Aluminium (raw or painted) – **lightweight, corrosion-resistant**, ideal for light vehicles
- Stainless steel (smooth or patterned) – perfect for applications requiring **maximum durability and a professional appearance**
- Steel (raw or painted) – suitable for particularly **robust structures**, intended for heavy-duty use and cost-effective solutions

Only upon customer request



HOW TO MEASURE YOUR ROLLER SHUTTER

SRS TOP

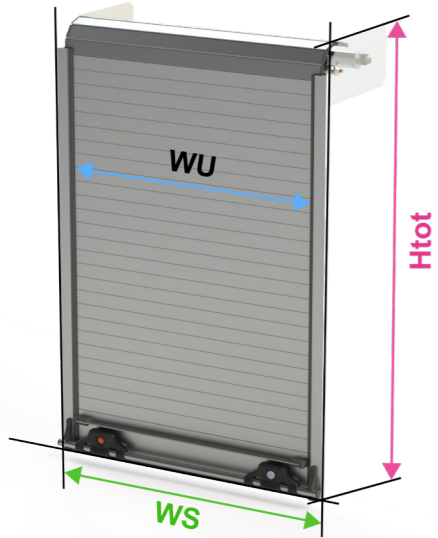

SRS TOP XL

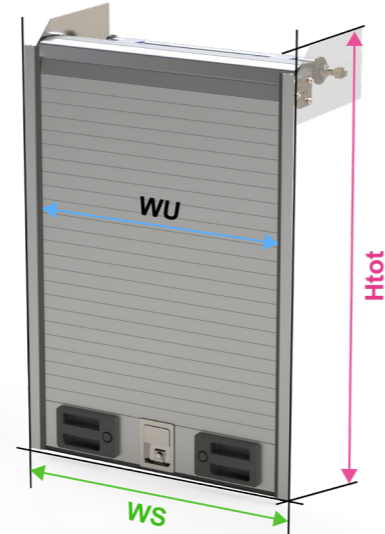

SRS TOP READY

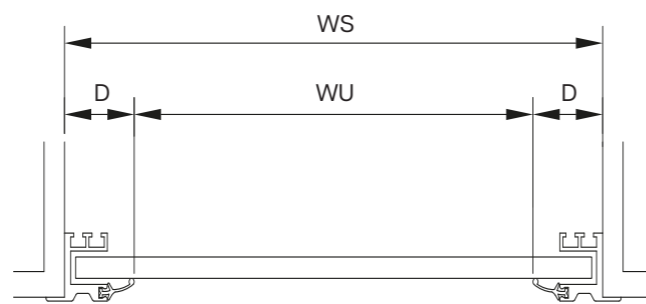
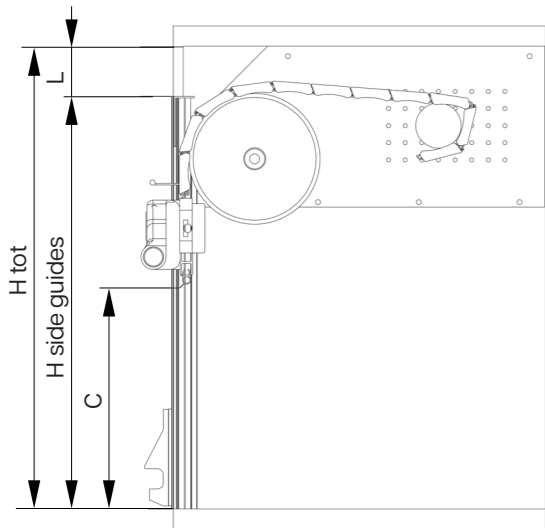
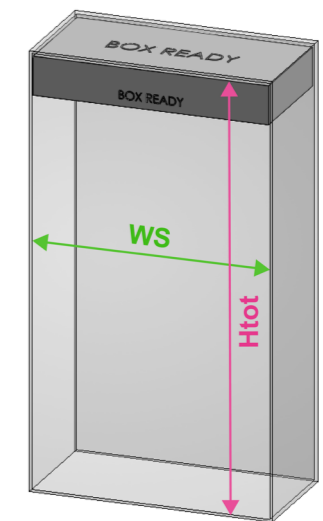

*The **measurements** and **fixing plates** from the **SRS TOP** are used for the **SRS TOP-E**

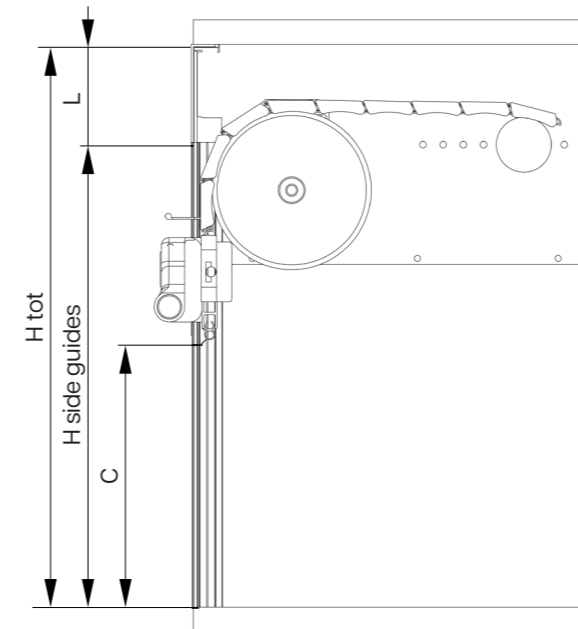

Fixing plate for **MP1** and **MP5**

*NOTE: In order to produce this shutter, the compartment must have precise dimensions because the tolerance is low, almost zero. A 3D or 2D drawing is valuable.

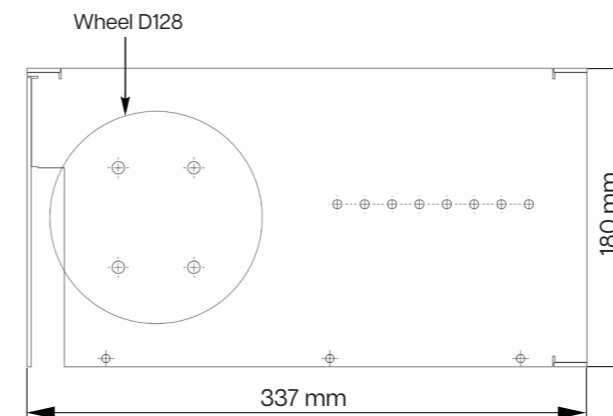
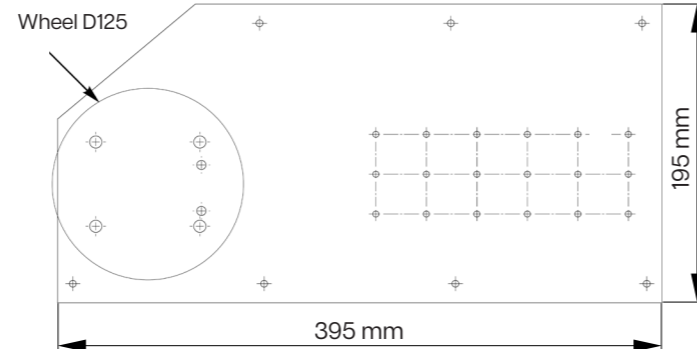
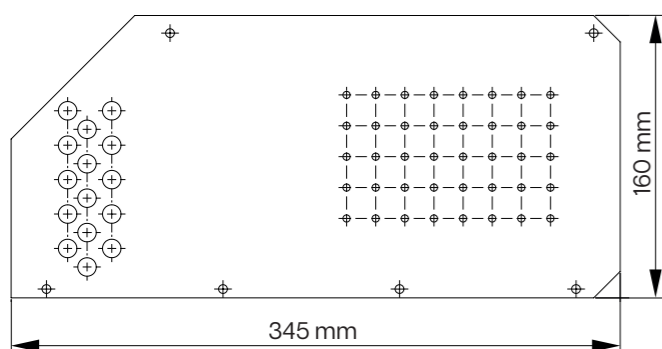

Measurements	
H tot	Total height
H guides	Side guides height
WU	Light width
WS	Total width
L	Sliding room
C	Light height
D	Guide and gasket edge

SRS ECO

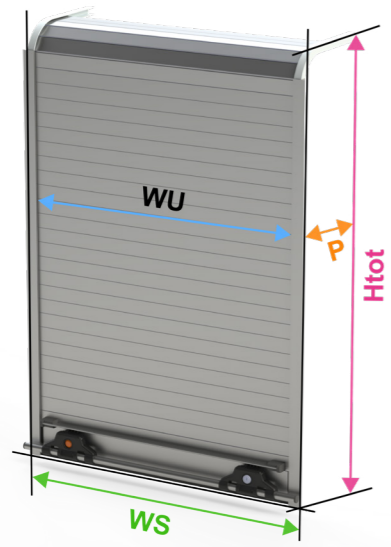

SRS ECO PLUS

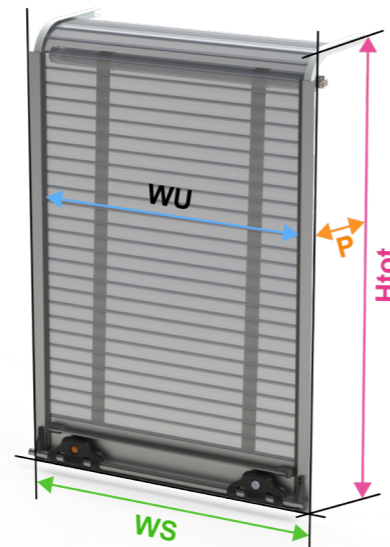

SRS ECO SIMPLY

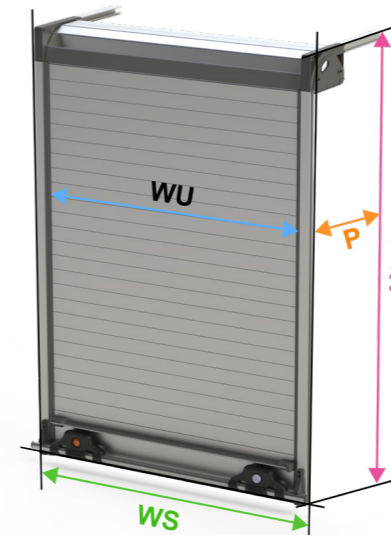

SRS ECO SIMPLY PLUS

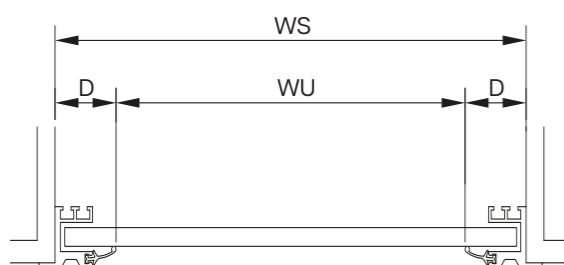
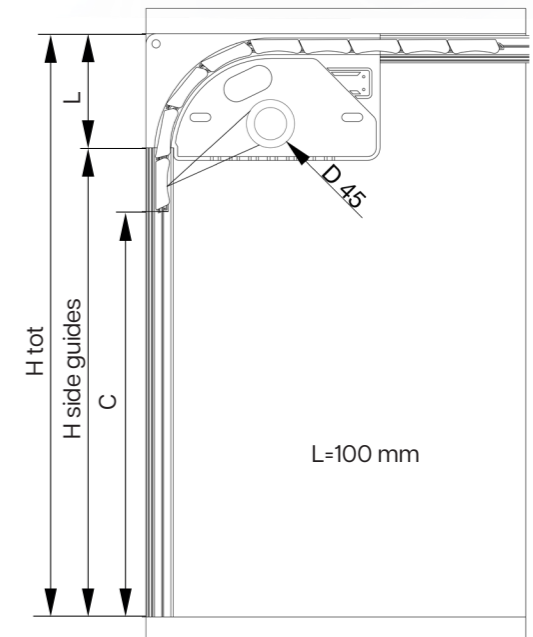
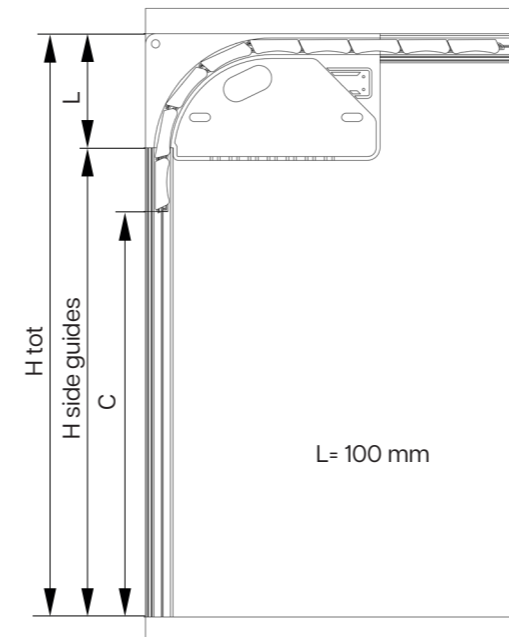
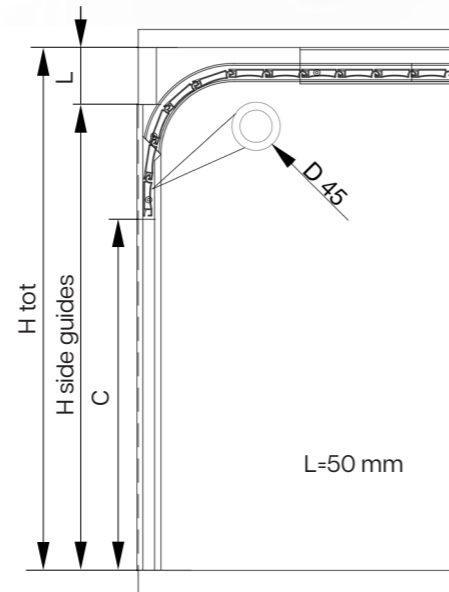
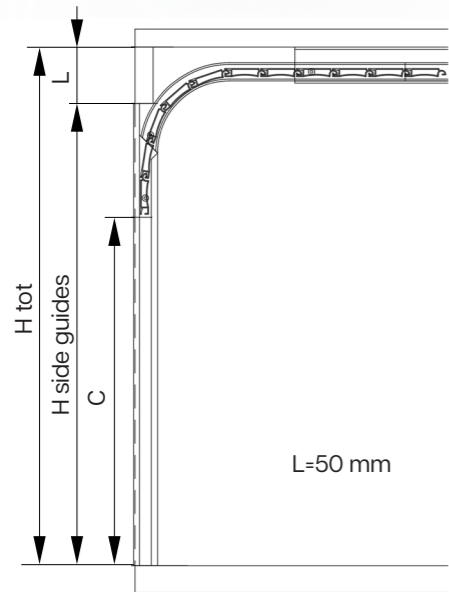
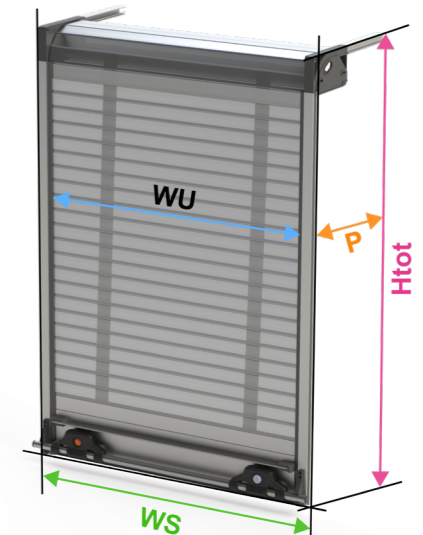

Measurements	
H tot	Total height
H guides	Side guides height
WU	Light width
WS	Total width
L	Sliding room
C	Light height
P	Depth
D	Guide and gasket edge

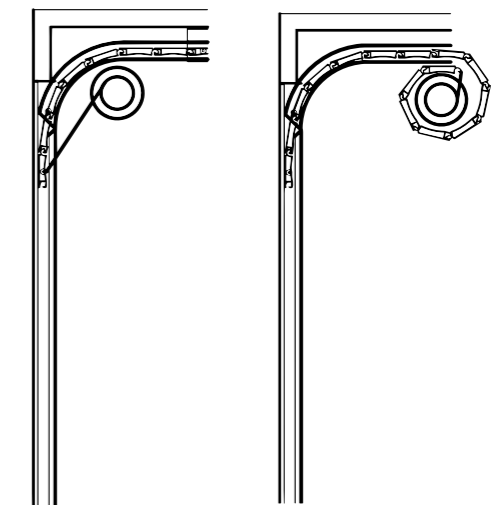
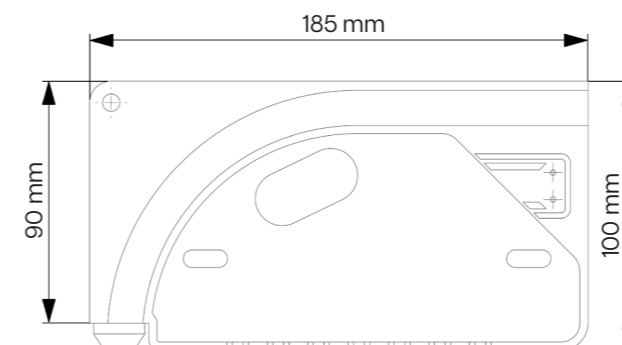





+39 030 2677496

info@serenaproduction.it

www.serenaproduction.it

www.srs-shutters.com

Via Benedetto Castelli 46
25010, Montirone, Brescia, Italia

