

ALUMINIUM ROLLER SHUTTERS

FOR SPECIAL VEHICLES



SRS
ROLLER SHUTTERS



06

OTHER ARTICLES

LADDERS
SLIDES
DRAWERS
LOCKING SYSTEMS
HOSE DIVIDERS
HANDRAILS
BOXES

A wide range of accessories are available, designed to complete and optimize the performance of our shutters. Each component is made from high-quality materials and can be customized according to the specific requirements of the installation.

LADDERS

Elevate26 Ladder – Excellence for Fire fighting and Rescue Vehicles

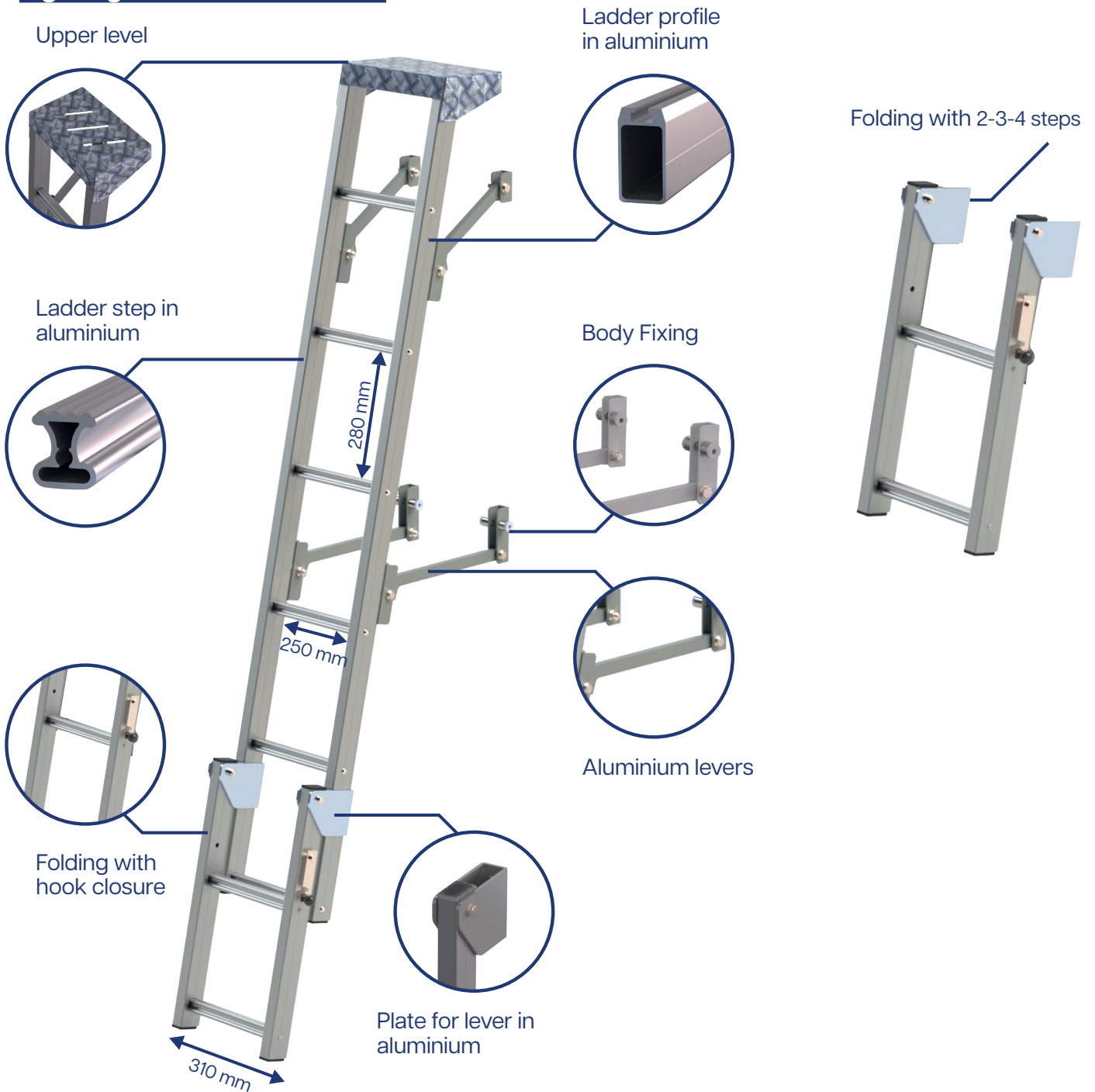

TECHNICAL FEATURES

| | | | |
|--------------------|----------------------------|--------------------|--------------------------------|
| Profile | Aluminium alloy EN-AW 6060 | Upper level | 310 x 180 mm, ribbed aluminium |
| Steps | 280 mm | Colour | Silver anodized |
| Total width | 310 mm | Max payload | 150 kg |

INCLINED UP & DOWN LADDER



TECHNICAL FEATURES

| | | | |
|--------------------|----------------------------|--------------------|--------------------------------|
| Profile | Aluminium alloy EN-AW 6060 | Upper level | 322 x 180 mm, ribbed aluminium |
| Steps | 303 mm | Colour | Silver anodized |
| Total width | 322 mm | Max payload | 120 kg |

FIXED LADDER



TECHNICAL FEATURES

| | | | |
|----------------|----------------------------|--------------------|---------------------|
| Profile | Aluminium alloy EN-AW 6060 | Upper level | Without upper level |
| Steps | 303 mm | Colour | Silver anodized |
| Width | 322 mm | Max payload | 120 kg |

SLIDES

The SRS extractable slides are designed for **maximum durability and functionality**, with a robust galvanized steel construction suitable for a wide range of professional applications. Available in multiple sizes and extraction configurations to meet operational requirements.

Applications

SRS slides can be used for:

- Cylinder holders
- Fire extinguisher holders
- Generator supports
- Pump holders
- SCBA (self-contained breathing apparatus) holders
- Welding equipment holders for doors
- Compressor holders
- General equipment and material storage

Available Sizes

Standard stock sizes:

- **700×470 mm** – full extension
- **750×540 mm** – full extension
- **410×850 mm** – with or without 6-position bracket, full or partial extraction
- **410×540 mm** – with or without 4-position bracket, full extraction

Dimensions refer to the support plate (first value indicating the handle side).

Customization

Custom slides can be produced to meet **specific customer requirements**.

All models are available with **pre-mounted brackets** or **as standalone plates**, depending on application.

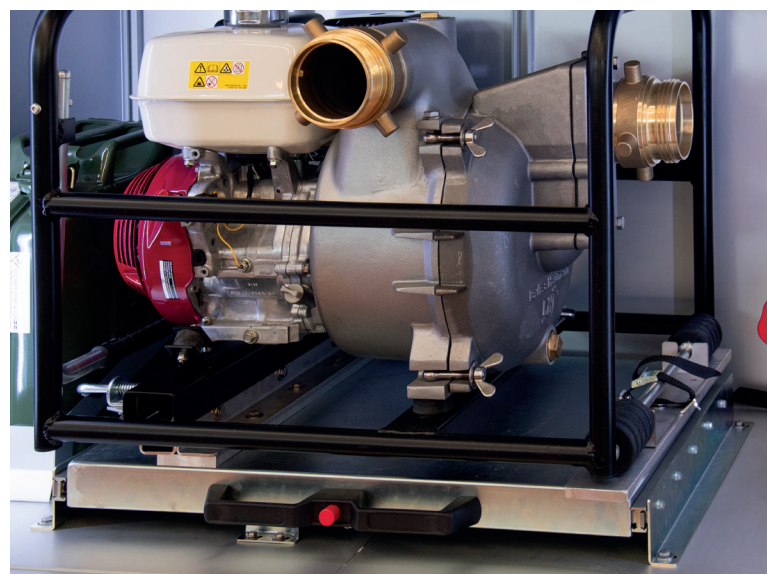
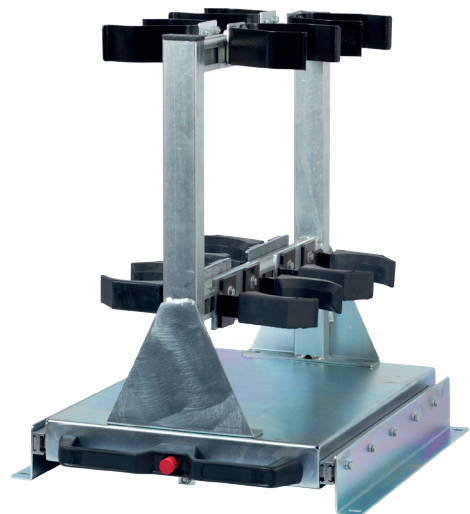
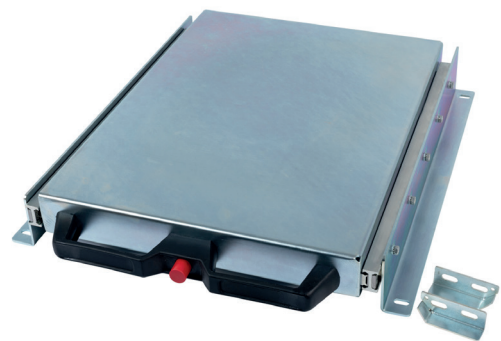
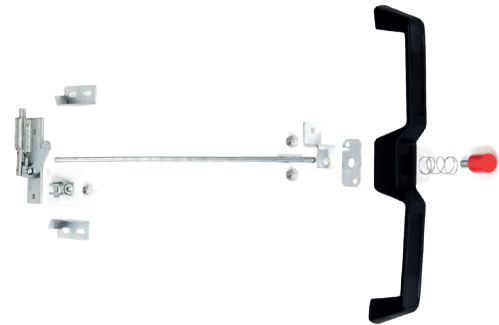

DRAWERS

The ribbed extruded drawers are made of **silver anodized aluminium profiles** with an almond-patterned aluminium bottom, and feature a **double-grip handle locking system**, available with or without key.

Each drawer is custom-made, allowing customers to choose width and depth, while the profile height remains fixed at 120 mm.

Available Sizes:

Width: **600 – 1500 mm**

Depth: **450 – 1000 mm**

Height: **120 mm** (fixed)

The drawers can be mounted on standard sliding systems or supplied with our tilting and sliding extraction system, which includes:

- Galvanized steel guides with polypropylene (PPL) strips for smooth sliding and proper weight distribution
- Nylon wheels and runners for stability and precise movement
- Full extraction and secure hooking at the end of the travel
- Safe tilting onto the top or shelf of the internal compartment for easy access and handling

This system ensures **smooth operation, precise positioning, and reliable load support**, even with heavy contents.

Customization

Drawers can be tailored to specific dimensions and integrated with accessories for a **versatile and durable storage solution**.



LOCKING SYSTEMS

SRS locking systems provide a **reliable and efficient solution** for doors and drawers in special vehicles, industrial fittings, and mobile units.

Available with or without key, each kit includes a **double-grip handle**, internal locking mechanism, and high-strength galvanized steel components.

Designed for **smooth operation and maximum safety**, these systems are compatible with all major opening solutions and can be supplied with red or black push-button, according to customer requirements.

LOCKING KIT WITH KEY



DRAWER KIT WITH KEY

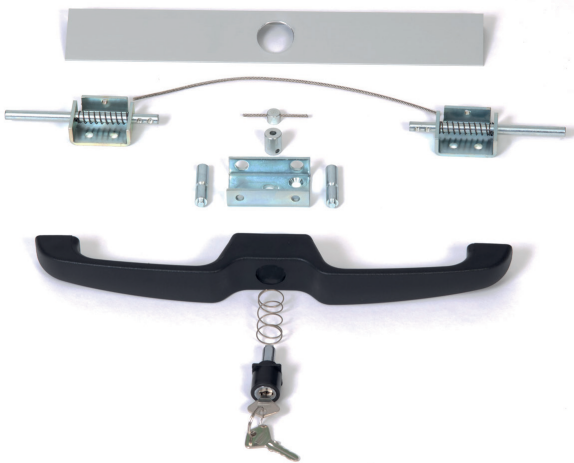

LOCKING KIT WITH RED BUTTON

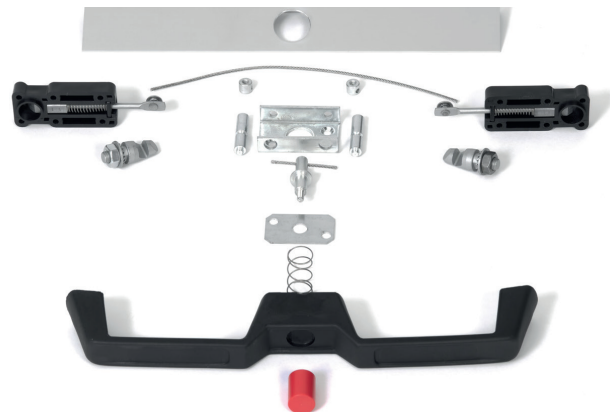

DRAWER KIT WITH BLACK OR RED BUTTON

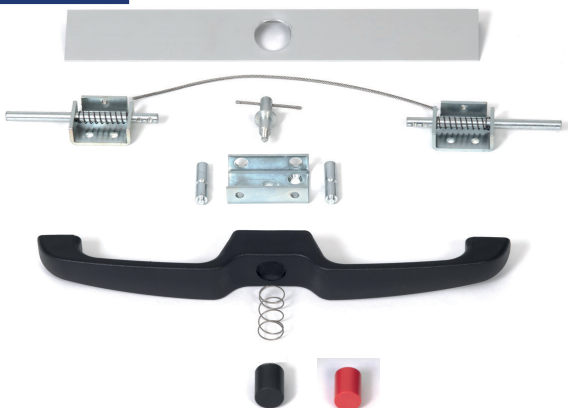

LOCKING KIT WITH BLACK BUTTON



HOSE DIVIDERS - HANDRAILS

Hose dividers

SRS hose dividers are designed to ensure **safe and organized hose storage** on board vehicles, improving accessibility and operational efficiency.

Available in two sizes:

- 465 × 500 mm
- 510 × 550 mm (on request)

They can be customized in the number and size of compartments, depending on the type of couplings installed.

Manufactured from **high-quality, durable materials**, they ensure long-lasting performance and ease of use, even in demanding operating conditions.

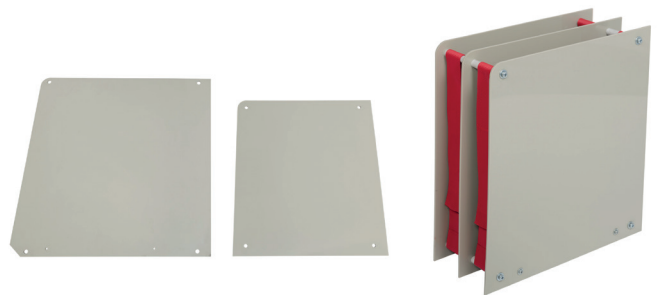

Handrails

SRS handrails are designed to complete vehicle fittings, providing **safety, ergonomics, and a clean, professional design**.

They can be custom-made according to customer specifications, with flexible configurations in length, height, and mounting type.

Manufactured from **anodized aluminium with high-strength technical supports**, they ensure stability, lightweight construction, and long-term durability.



BOXES

Serena Production can supply not only the shutter with its related accessories, but also the **complete box, ready for use** and perfectly optimized in every component.

Each solution is **custom-designed** and can be manufactured in different types of materials, with raw finishes or powder-coated in customized RAL colors, according to specific customer requirements:

- Aluminium (raw or painted) – **lightweight, corrosion-resistant**, ideal for light vehicles
- Stainless steel (smooth or patterned) – perfect for applications requiring **maximum durability and a professional appearance**
- Steel (raw or painted) – suitable for particularly **robust structures**, intended for heavy-duty use and cost-effective solutions

Only upon customer request







+39 030 2677496

info@serenaproduction.it

www.serenaproduction.it

www.srs-shutters.com

Via Benedetto Castelli 46
25010, Montirone, Brescia, Italia

